

# HAFCO METALMASTER



Edition : 1.0  
Date: (07/25)

## Instruction Manual

# CENTRE LATHE AL-346V

Order Code: (L555D)

**MACHINE DETAILS**

<b>MACHINE.</b>	CENTRE LATHE
<b>MODEL NO.</b>	AL-346V
<b>SERIAL NO.</b>	
<b>DATE OF MANF.</b>	

IMPORTED BY



[www.machineryhouse.com.au](http://www.machineryhouse.com.au)



[www.machineryhouse.co.nz](http://www.machineryhouse.co.nz)

**NOTE:**

*This manual is only for your reference. At the time of the compiling of this manual every effort to be exact with the instructions, specifications, drawings, and photographs of the machine was taken. Owing to the continuous improvement of the HAFCO METALMASTER machine, changes may be made at any time without obligation or notice. Please ensure the local voltage is the same as listed on the specification plate before operating any electric machine.*

**SAFETY SYMBOLS:**

*The purpose of safety symbols is to attract your attention to possible hazardous conditions*



**WARNING** Indicates a potentially hazardous situation causing injury or death



**CAUTION** Indicates an alert against unsafe practices.

**Note:** Used to alert the user to useful information



**NOTE:**

*In order to see the type and model of the machine, please see the specification plate. Usually found on the back of the machine. See example (Fig.1)*

Fig.1

**HAFCO**  
**METALMASTER**

---

**PRODUCT SPECIFICATIONS**

Model: AL-346V	Voltage: 240V/50Hz	
Capacity: 330x1000mm	Motor: 1.5kW	
Nett Weight: 636kg	FLC: 5.7A	
MFG Date:		

**Serial No:**

---

Imported by <a href="http://www.machineryhouse.com.au">www.machineryhouse.com.au</a>	Made in China <a href="http://www.machineryhouse.co.nz">www.machineryhouse.co.nz</a>
---	---

**CONTENTS:**

**1. GENERAL MACHINE INFORMATION**

1.1 Specifications ..... 4

1.2 Identification ..... 5

**2. SAFETY**

2.1 General Metalworking Machine Safety ..... 6

2.2 Specific Safety For Lathes ..... 9

**3. POWER SUPPLY**

3.1 Electrical Installation ..... 10

3.2 Full Load Current ..... 10

**4. SETUP**

4.1 Unpacking ..... 11

4.2 Included Accessories ..... 11

4.3 Clean Up ..... 11

4.4 Site Preparation ..... 11

4.5 Lifting Instructions ..... 12

4.6 Anchoring To The Floor ..... 13

4.7 Machine Levelling ..... 13

4.8 Assembly ..... 14

**5. OPERATION**

5.1 Controls ..... 15

5.2 Chuck and Faceplate Mounting ..... 19

5.3 Setting Cutting Tool To Spindle Centerline.. 21

5.4 Spindle Speeds ..... 22

5.5 Threading ..... 23

5.6 Change Gears ..... 25

5.7 Selecting The Feeds ..... 26

5.8 Quick Change Toolpost ..... 27

5.9 Aligning Tailstock to Spindle Centerline..... 28

5.10 Removing & Replacing The Bed Gap ..... 29

5.11 Optional Tooling. .... 29

5.12 Coolant System. .... 31

**6. MAINTENANCE**

6.1 Lubrication ..... 32

6.2 Lubrication Points ..... 33

6.3 Troubleshooting ..... 36

6.4 Adjustments ..... 37

    Slide Way Gibs ..... 37

    Cross Slide Nut ..... 38

    Feed Clutch ..... 38

    V-Belts ..... 39

    Half Nut ..... 39

**SPARE PARTS**

Bed Assembly Diagram ..... 41

Bed Assembly Parts List ..... 41

Headstock 1 Diagram ..... 42

Headstock 1 Parts List ..... 43

Headstock 2 Diagram ..... 45

Headstock 2 Parts List ..... 46

Gearbox 1 Parts Diagram ..... 47

Gearbox 2 Parts Diagram ..... 48

Gearbox Parts List ..... 49

Apron Diagram ..... 51

Apron Parts List ..... 52

Compound Rest Diagram ..... 54

Compound Rest Parts List ..... 55

Saddle Parts Diagram ..... 56

Saddle Parts List ..... 57

Tailstock Parts Diagram ..... 58

Tailstock Spare Parts List ..... 59

Change Gears Diagram ..... 60

Change Gears Parts List ..... 60

Control Switch Assembly Diagram ..... 61

Control Switch Assembly Parts List ..... 62

Bed and Drive Assembly Diagram ..... 63

Bed and Drive Assembly Parts List ..... 64

Stand, Coolant Pump & Lamp Diagram ..... 65

Stand, Coolant Pump & Lamp Parts List ..... 67

Electrical Assembly 1 Diagram ..... 68

Electrical Assembly Parts List ..... 69

Electrical Assembly 2 Diagram ..... 70

Electrical Assembly Parts List ..... 70

Steady Rest Diagram ..... 71

Steady Rest Parts List ..... 72

Follow Rest Diagram & Parts List ..... 73

Chuck Safety Guard Diagram & Parts List ..... 74

Leadscrew Cover Diagram & Parts List ..... 75

Feed Rod Clutch Diagram & Parts List ..... 76

Quick Change Toolpost Diagram & Parts List. . 77

Saddle Position Stop Diagram & Parts List..... 78

**Risk Assessment Sheets ..... 79**

## 1.1 SPECIFICATIONS

Order Code	L555D
<b>MODEL</b>	<b>AL-346V</b>
Swing Over Bed (mm)	330
Distance Between Centres (mm)	1000
Spindle Bore (mm)	40
Swing In Gap (mm)	450
Swing Over Cross-slid (mm)	200
Digital Readout System Fitted	Yes
Quick Change Toolpost Fitted	Yes
Tool Height To Suit (mm)	16
Centre Height (mm)	165
Spindle Nose Size or Type Camlock	D1-4
Bed Width (mm)	181
Headstock Spindle Taper (MT)	5
Tailstock Taper (MT)	3
Cross Slide Travel (mm)	160
Compound Slide Travel (mm)	85
Leadscrew Type	Metric
Metric Cross Feed (X-Axis) (mm / rev)	0.013 / 0.31
Metric Longitudinal Feed (Z-Axis) (mm / rev)	0.053 - 1.29
Metric Thread Steps & Pitch (No. / mm)	32 (0.4 - 7)
Imperial Thread Steps & TPI (No. / TPI)	36 (4 - 60)
3 Jaw Chuck Diameter (mm)	160
4 Jaw Chuck Diameter (mm)	200
Spindle Steps / Speeds (No. / rpm)	Variable (70 - 2000)
Motor Power (kW / hp)	1.5 / 2
Voltage / Amperage (V / Amp)	240 / 10
Dimensions (L x W x H) (mm)	1870 x 740 x 1565
Nett Weight (kg)	610

## 1.2 IDENTIFICATION

Become familiar with the names and locations of the controls and features shown below to better understand the instructions when mentioned later in this manual.

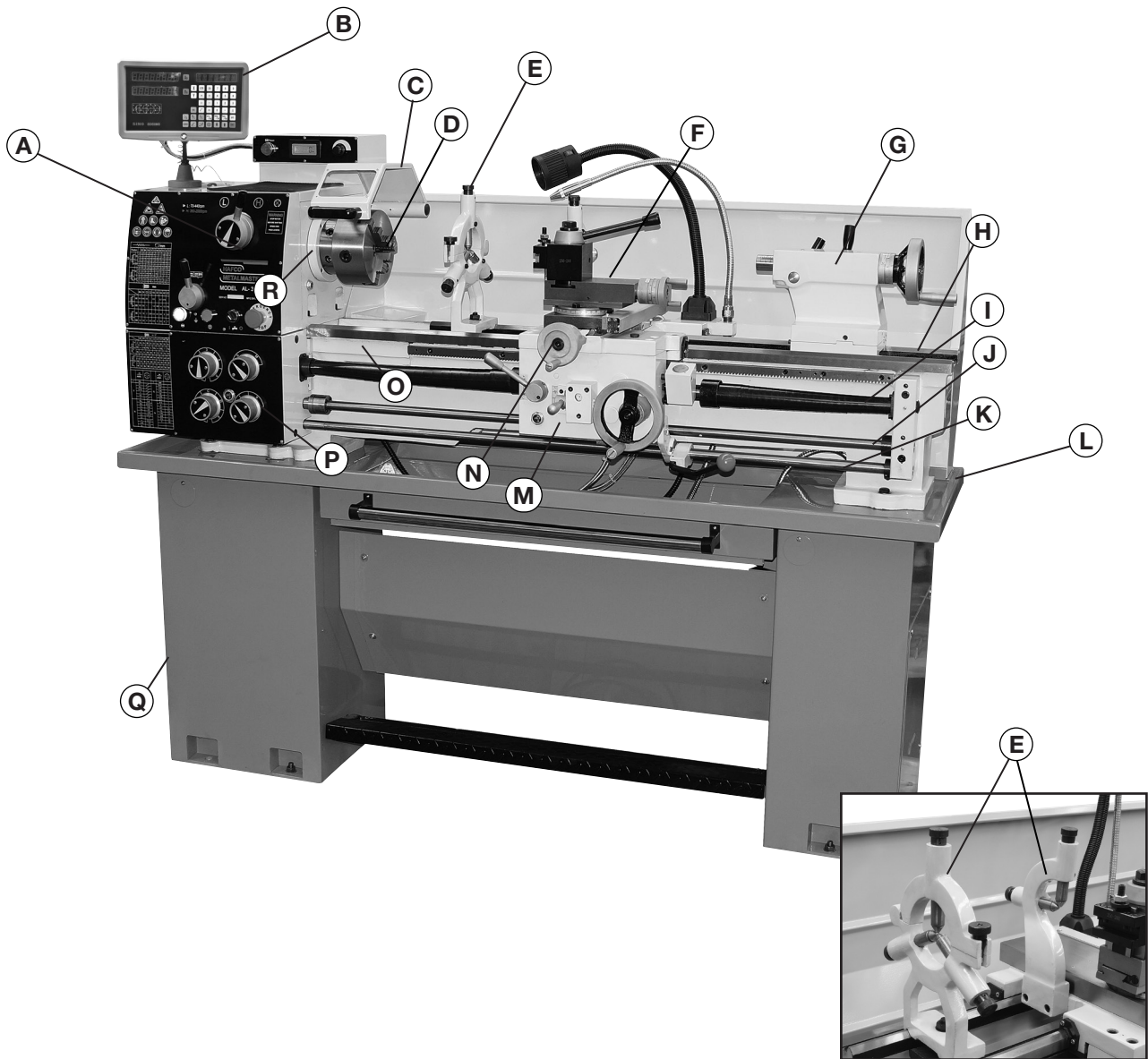

<b>A</b>	Headstock	<b>J</b>	Feed Shaft
<b>B</b>	HAFCO Digital Readout Display	<b>K</b>	Start and Stop Shaft
<b>C</b>	Chuck Safety Guard	<b>L</b>	Swarf Tray
<b>D</b>	3 Jaw Chuck	<b>M</b>	Saddle
<b>E</b>	Fixed & Travelling Steadies	<b>N</b>	Cross Slide
<b>F</b>	Top Slide	<b>O</b>	Bed Gap
<b>G</b>	Tailstock	<b>P</b>	Feed Gearbox
<b>H</b>	Bed	<b>Q</b>	Stand
<b>I</b>	Leadscrew	<b>R</b>	Spindle

## 2. SAFETY

### 2.1 GENERAL METALWORKING MACHINE SAFETY

DO NOT use this machine unless you have read this manual or have been instructed in the use of this machine in its safe use and operation.



## WARNING!

This manual provides safety instructions on the proper setup, operation, maintenance, and service of this machine. Save this manual, refer to it often, and use it to instruct other operators.

Failure to read, understand and follow the instructions in this manual may result in fire or serious personal injury, including amputation, electrocution, or death.

The owner of this machine is solely responsible for its safe use. This responsibility includes, but is not limited to proper installation in a safe environment, personnel training and authorization to use, proper inspection and maintenance, manual availability and comprehension, of the application of the safety devices, integrity, and the use of personal protective equipment.

The manufacturer will not be held liable for injury or property damage from negligence, improper training, machine modifications or misuse.



- ✓ Always wear safety glasses or goggles.
- ✓ Wear appropriate safety footwear.
- ✓ Wear respiratory protection where required.
- ✓ Gloves should never be worn while operating the machine, and only worn when handling the work piece.
- ✓ Wear hearing protection in areas > 85 dBA. If you have trouble hearing someone speak from one metre (three feet) away, the noise level from the machine may be hazardous.
- ✓ DISCONNECT THE MACHINE FROM POWER when making adjustments or servicing.
- ✓ Check and adjust all safety devices before each job.
- ✓ Ensure that guards are in position and in good working condition before operating.
- ✓ Ensure that all stationary equipment is anchored securely to the floor.
- ✓ Ensure all machines have a start/stop button within easy reach of the operator.
- ✓ Each machine should have only one operator at a time. However, everyone should know how to stop the machine in an emergency.

## 2.1 GENERAL SAFETY REQUIREMENTS CONT.

- ✓ Ensure that keys and adjusting wrenches have been removed from the machine before turning on the power. Appropriate storage for tooling should be provided.
- ✓ Ensure that all cutting tools and blades are clean and sharp. They should be able to cut freely without being forced.
- ✓ Stop the machine before measuring, cleaning or making any adjustments.
- ✓ Wait until the machine has stopped running to clear cuttings with a vacuum, brush or rake.
- ✓ Keep hands away from the cutting head and all moving parts.
- ✓ Avoid awkward operations and hand positions. A sudden slip could cause the hand to move into the cutting tool or blade.
- ✓ Return all portable tooling to their proper storage place after use.
- ✓ Clean all tools after use.
- ✓ Keep work area clean. Floors should be level and have a non-slip surface.
- ✓ Use good lighting so that the work piece, cutting blades, and machine controls can be seen clearly. Position any shade lighting sources so that they do not cause any glare or reflections.
- ✓ Ensure there is enough room around the machine to do the job safely.
- ✓ Obtain first aid immediately for all injuries.
- ✓ Understand that the health and fire hazards can vary from material to material. Make sure all appropriate precautions are taken.
- ✓ Clean machines and the surrounding area when the operation is finished.
- ✓ Use proper lock out procedures when servicing or cleaning the machines or power tools.

### DO NOT

- × Do not distract an operator. Horseplay can lead to injuries and should be strictly prohibited.
- × Do not wear loose clothing, gloves, neckties, rings, bracelets or other jewellery that can become entangled in moving parts. Confine long hair.
- × Do not handle cuttings by hand because they are very sharp. Do not free a stalled cutter without turning the power off first. Do not clean hands with cutting fluids.
- × Do not use rags or wear gloves near moving parts of machines.
- × Do not use compressed air to blow debris from machines or to clean dirt from clothes.
- × Do not force the machine. It will do the job safer and better at the rate for which it was designed.



### **CAUTION!**

***It is impossible to cover all possible hazards Every workshop environment is different. These are designed as a guide to be used to compliment training and as a reminder to users prior to equipment use. Always consider safety first, as it applies to the individual working conditions.***



### **WARNING!**

***Before operating any machine, take time to read and understand all safety signs and symbols. If not understood seek explanation from your supervisor or an experienced operator.***

## 2.1 GENERAL SAFETY REQUIREMENTS Cont.

**HAZARDS ASSOCIATED WITH MACHINES** include, but are not limited to:

- Being struck by ejected parts of the machinery.
- Being struck by material ejected from the machinery.
- Contact or entanglement with the machinery.
- Contact or entanglement with any material in motion.

**Health Hazards** (other than physical injury caused by moving parts)

- Chemicals hazards that can irritate, burn, or pass through the skin.
- Airborne items that can be inhaled, such as oil mist, metal fumes, solvents, and dust.
- Heat, noise, and vibration.
- Ionizing or non-ionizing radiation. (X-ray, lasers, etc.)
- Biological contamination and waste.
- Soft tissue injuries (for example, to the hands, arms, shoulders, back, or neck) resulting from repetitive motion, awkward posture, extended lifting, and pressure grip.

**Other Hazards**

- Slips and falls from and around machinery during maintenance.
- Unstable equipment that is not secured against falling over.
- Safe access to/from machines. (access, egress)
- Fire or explosion.
- Pressure injection injuries from the release of fluids and gases under high pressure.
- Electrical Hazards, such as electrocution from faulty or ungrounded electrical components.
- Environment in which the machine is used. (in a machine shop, or on a work site)



### **WARNING!**

*The machine is the sole responsibility of the owner for its safe use. This responsibility includes but is not limited to proper installation in a safe environment, personnel training, proper inspection and maintenance, manual availability and comprehension. The manufacturer will not be held liable for injury or property damage from negligence, improper training, machine modifications or misuse.*



### **WARNING!**

*Machines are safeguarded to protect the operator from injury or death with the placement of guards. Machines must not be operated with the guards removed or damaged.*

## 2.2 SPECIFIC LATHE SAFETY

**DO NOT use this machine unless you have been instructed in its safe use and operation and have read and understood this manual**



*Safety glasses must be worn at all times in work areas*



*Long and loose hair must be contained*



*Gloves must not be worn when using this machine*



*Sturdy footwear must be worn at all times in work areas*



*Close fitting/protective clothing must be worn*



*Rings and jewelry must not be worn.*

### PRE-OPERATIONAL SAFETY CHECKS

- ✓ Locate and ensure you are familiar with all machine operations and controls.
- ✓ Ensure all guards are fitted, secure and functional. Do not operate if guards are missing or faulty.
- ✓ Check workspaces and walkways to ensure no slip/trip hazards are present.
- ✓ Check the job is clamped tight in the chuck.
- ✓ Remove all tools from the bed and slides of the machine.
- ✓ Ensure the correct speed for machining process is selected.
- ✓ Remove the chuck key before starting the lathe.

### OPERATIONAL SAFETY CHECKS

- ✓ Before making adjustments or measurements, switch off and bring the machine to a complete standstill.
- ✓ Always remove the chuck key from the chuck.

### ENDING OPERATIONS AND CLEANING UP

- ✓ Switch off the machine when work completed.
- ✓ Reset all guards to a fully closed position.
- ✓ Avoid letting swarf build up on the tool or job. Stop the machine and remove it.
- ✓ Leave the machine in a safe, clean and tidy state.

### DON'T

- ✗ **Do not** use faulty equipment. Immediately report suspect machinery.
- ✗ **Do not** try to lift chucks or face plates that are too heavy for you.
- ✗ **Do not** leave the machine running unattended.
- ✗ **Do not** attempt to slow or stop the chuck or revolving work by hand.
- ✗ **Do not** leave equipment on top of the machine.

### POTENTIAL HAZARDS AND INJURIES

- Flying objects such as the chuck key left in chuck.
- Cutting tool injury when cleaning, filing or polishing.
- Hair/clothing getting caught in moving machine parts.
- Metal splinters and swarf.
- Eye Injuries.

### 3. POWER SUPPLY

#### 3.1 ELECTRICAL INSTALLATION

Place the machine near an existing power source. Make sure all power cords are protected from traffic, material handling, moisture, chemicals, or other hazards. Make sure there is access to a means of disconnecting the power source. The electrical circuit must meet the requirements for 240V.

**NOTE : The use of an extension cord is not recommended as it may decrease the life of electrical components on your machine.**

#### ELECTRICAL REQUIREMENTS

Nominal Voltage.....	240V
Cycle.....	50 Hz
Phase.....	Single Phase
Power Supply Circuit.....	10 Amps
Full Load Current.....	5.7 Amps

(Full load current rating is also on the specification plate on the motor.)

#### 3.2 FULL-LOAD CURRENT RATING

The full-load current rating is the amperage a machine draws when running at 100% of the output power. Where machines have more than one motor, the full load current is the amperage drawn by the largest motor or a total of all the motors and electrical devices that might operate at one time during normal operations.

Full-Load Current Rating for these machine at 240V is 5.7 Amps. It should be noted that the full-load current is not the maximum amount of amps that the machine will draw. If the machine is overloaded, it will draw additional amps beyond the full-load rating and if the machine is overloaded for a long period of time, damage, overheating, or fire may be caused to the motor and circuitry.

This is especially true if connected to an undersized circuit or a long extension lead. To reduce the risk of these hazards, avoid overloading the machine during operation and make sure it is connected to a power supply circuit that meets the requirements.



## 4 SETUP

### 4.1 UNPACKING

This machine was carefully packaged for safe transport. When unpacking, separate all enclosed items from packaging materials and inspect them for shipping damage. If items are damaged, please contact your distributor.

**NOTE: Save all the packaging materials until you are completely satisfied with the machine and have resolved any issues with the distributor, or the shipping agent.**

When unpacking, check the packing list to make sure that all parts shown are included. If any parts are missing or broken, please contact your distributor.

### 4.2 INCLUDED ACCESSORIES

160mm 3-jaw chuck with reverse jaws	Toolbox and instruction booklet
200mm 4-jaw chuck	Swarf tray
Face plate	Thread-chasing dial
Fixed and travelling steadies	Chuck guard
Change gears	2 Axis Digital Readout
Dead centre	Leadscrew Covers
Cabinet stand	
Splash tray	

### 4.3 CLEAN - UP

The unpainted surfaces of the machine have been coated with a waxy oil to protect them from corrosion during shipment. Remove the protective coating with a solvent cleaner or a citrus based degreaser.

Optimum performance from your machine will be achieved when you clean all moving parts or sliding contact surfaces that are coated with rust prevented products.

It is advised to avoid chlorine based solvents, such as acetone or brake parts cleaner, as they will damage painted surfaces and strip metal should they come in contact. Always follow the manufacturer's instructions when using any type of cleaning product.

### 4.4 SITE PREPARATION

When selecting the site for the machine, consider the largest size of workpiece that will be processed through the machine and provide enough space around the machine for operating the machine safely. Consideration should be given to the installation of auxiliary equipment.

Leave enough space around the machine to open or remove doors/covers as required for the maintenance and service as described in this manual.

It is recommended that the machine is anchored to the floor to prevent tipping or shifting. It also reduces vibration that may occur during operation.

## 4.5 LIFTING INSTRUCTIONS

On the day that the machine arrives, make sure that a crane or forklift with sufficient capacity is available to unload the machine from the vehicle. Ensure access to the chosen site is clear and that doors and ceilings are sufficiently high and wide enough to receive the machine.

To handle the machine, the slings should be positioned so the machine is level when lifted.

### LIFTING POINT

To obtain a balanced condition before lifting, it is necessary to move the tailstock to the right hand end of the bed way and clamp it there. Make sure to clean the bed ways before moving the carriage or tailstock. Use approved webbed slings to lift the lathe. Position the saddle and tailstock along the bed to obtain the balance. Raising and lowering the machine should be done carefully, especially when you are lowering the machine. Be sure not to bump the machine against the floor.

**Important: Do not use slings around the bed as leadscrew and feed shaft may be bent.**



FIG. 4.2

 <b>WARNING</b>	
<b>SAFETY FIRST</b>	<i>The safety instructions given in this manual can not be complete. The environment in every shop is different. Always consider your safety first as it applies to your individual working conditions.</i>
	

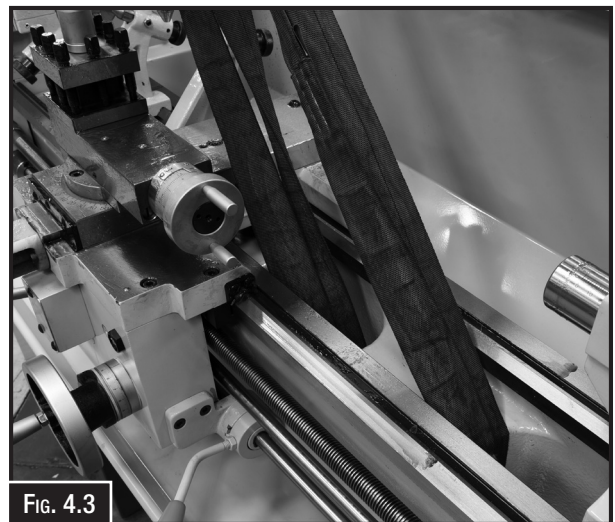

FIG. 4.3



### **WARNING!**

***Make sure everyone is away from the load before hoisting. The load must be under control when lowering loads or when the load is suspended. Rigging and crane operation must be carried out by persons with approved qualifications.***

## 4.6 ANCHORING TO THE FLOOR

### OPTIONS FOR MOUNTING

The machine is best mounted on a concrete slab. Masonry anchors with bolts are the best way to anchor machinery, because the anchors sit flush with the floor surface, making it easy to unbolt and move the machine later, if needed. (Fig. 4.4)

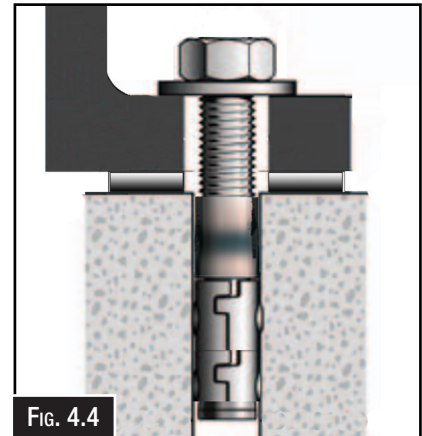

FIG. 4.4

## 4.7 MACHINE LEVELING

To set your machine up so that it operates to optimum performance, apply the following procedure.

After your machine has been anchored to a concrete slab floor, it then needs to be levelled. Loosen the hold down bolts and place a level on the surface of the Lathe bed. Metal shims need to be placed under the corner of the base of the machine until level. Once level and the machine is stable then tighten the hold down bolts. (Fig. 4.5).

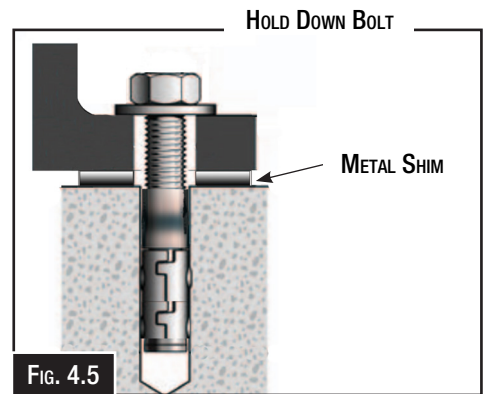
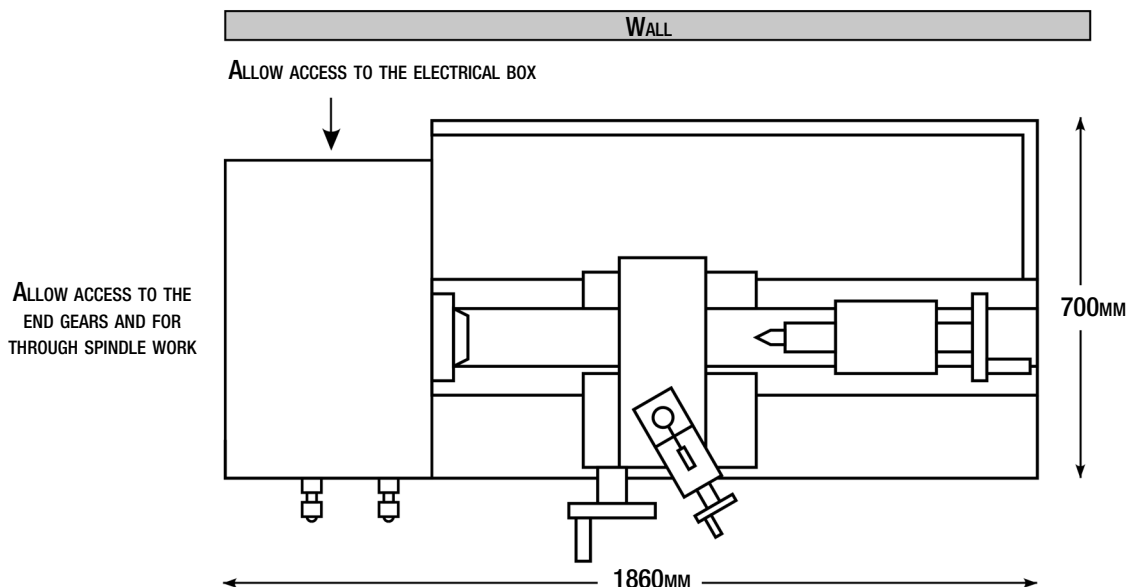

FIG. 4.5

## Floor Plan



## 4.8 ASSEMBLY

The machine must be fully assembled before it can be operated. First clean any parts that are coated in rust preventative to ensure the assembly process can proceed smoothly.

### Mounting The Digital Readout

Disconnect the machine from the power before installing the DRO.

The Digital Readout will need to be fitted using the bracket on the top of the head. (Fig. 4.6)

**NOTE: In some cases the machine may be supplied fully assembled and may only require the fitting of the chuck to the spindle.**



Fig. 4.6

### Assemble Handles. (Fig.4.7)

Assembly required will be the bolting on of the handles. Using a screwdriver assemble each handle on the handwheels of the machine.

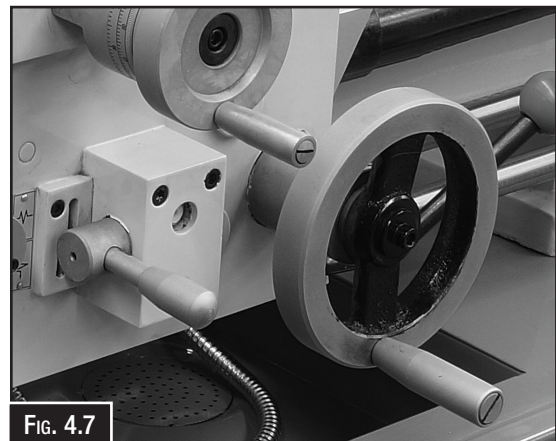

Fig. 4.7

## 5. OPERATION

This machine may perform many types of operations that are beyond the scope of this manual. Many of these operations may be dangerous or deadly if performed incorrectly.

The instructions in this section are written with the understanding that the operator has the necessary knowledge and skills to operate this machine. If at any time you are experiencing difficulties performing any operation, stop using the machine!

If you are an inexperienced operator, we strongly recommend that you read books, trade articles, or seek training from an experienced operator before performing any unfamiliar operations.

**Above all, your safety should come first!**

## 5.1 CONTROLS

The purpose of this control overview is to provide the novice machine operator with a basic understanding of how the machine is used during operation, and the machine controls and what they do. It also helps the operator to understand if they are discussed later in this manual.

**NOTE: DO NOT start the machine until all of the setup instructions have been performed.**

### HEADSTOCK ELECTRICAL CONTROLS Fig.5.1

1. **Pilot Lamp:** Illuminates when power is connected to the control panel.
2. **Jog Button:** Allows for the spindle to be rotated in small amounts.
3. **Coolant Switch:** Switches the coolant On or OFF.
4. **Emergency Stop Button:** When pressed disconnects power to the control panel and stops the machine. To reset the stop button the top of the stop button must be twisted to allow the button to pop up.



Fig. 5.1

### HEADSTOCK SPEED CONTROLS Fig.5.2

5. **Reset Button:** When pressed resets the speed control back to zero.
6. **Digital Display:** Displays the spindle speed in RPM.
7. **Speed Control Knob:** Adjusts the speed when rotated.
8. **High/Low Speed Control:** Adjusts the speed between High and Low range. (Fig. 5.3)

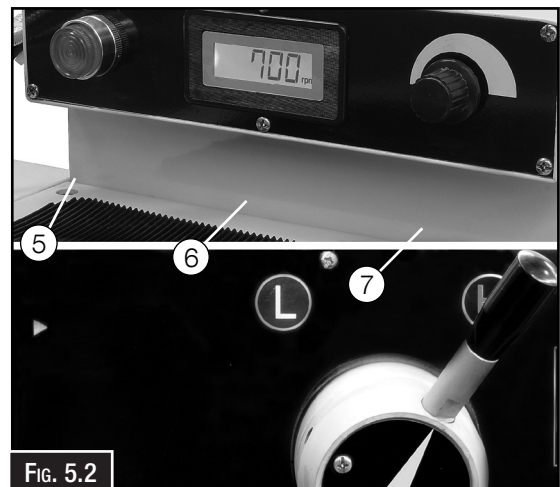

Fig. 5.2

<b>! WARNING</b>	
<b>SAFETY FIRST</b>	<p><i>The safety instructions given in this manual can not be complete. The environment in every shop is different. Always consider your safety first as it applies to your individual working conditions.</i></p>
<b>SAFETY FIRST</b>	



Fig. 5.3

SADDLE (Fig. 5.4)

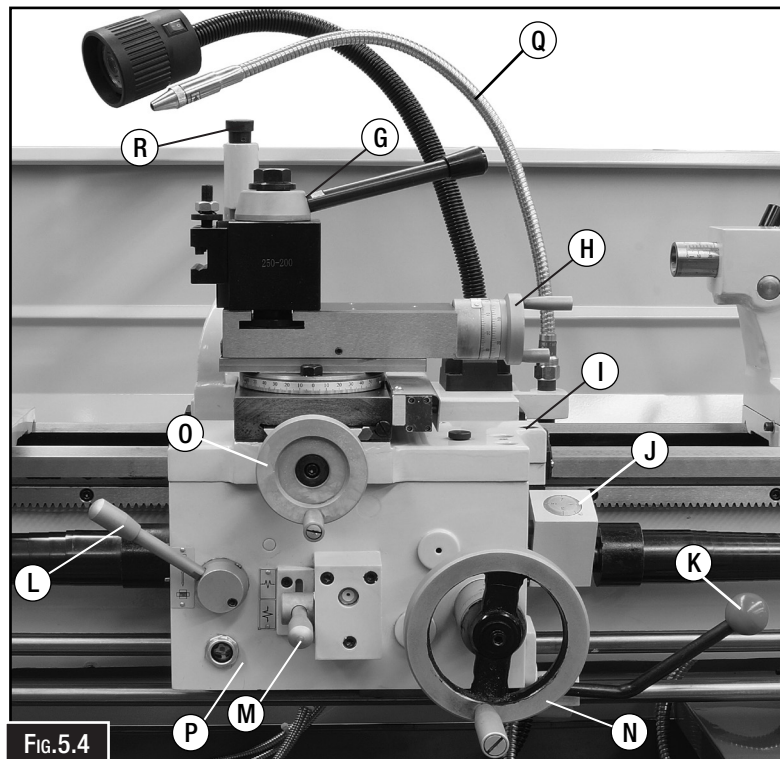

- G. **Quick Change Tool Post:** Allows the operator to load and unload tools.
- H. **Compound Rest Hand wheel:** Moves the tool toward and away from the work-piece at the pre-set angle of the compound rest.
- I. **Carriage Lock:** Secures the carriage in place for greater rigidity when it should not move.
- J. **Thread Dial:** Indicates when to engage the half nut during threading operations.
- K. **Spindle Lever:** Starts, stops and reverses direction of spindle rotation.
- L. **Half Nut Lever:** Engages/disengages the half nut for threading operations.
- M. **Feed Selection Lever:** Selects the carriage or cross slide for power feed.
- N. **Carriage Hand wheel:** Moves the carriage along the bed.
- O. **Cross Slide Hand wheel:** Moves the cross slide toward and away from the work-piece.
- P. **Apron:** Houses the carriage gearing.
- Q. **Coolant Hose:** Flexible coolant hose, that travels with the saddle.
- R. **Traveling Steady:** Travels with the saddle and is used to support thin materials and sits opposite the tool.

### Spindle ON/OFF Lever (Fig. 5.5)

Starts and stops the spindle in forward and reverse.

- Moving the lever upward from the central OFF position spins the chuck forward (the top of the chuck moves toward the machinist).
- Moving the lever downward from the central OFF position spins the chuck in reverse (the top of the chuck moves away from the machinist).



Fig. 5.5

### Foot Brake (Fig. 5.6)

This lathe is equipped with a foot brake to quickly stop the spindle. Pushing the foot brake while the spindle is ON cuts power to the motor and stops the spindle. Once stopped, the spindle ON/OFF lever MUST be returned to the neutral position before the spindle can be restarted.

#### **WARNING!**

**USING THE FOOT BRAKE TO STOP THE LATHE REDUCES RISK OF AN ENTANGLEMENT INJURY FROM ALLOWING THE LATHE TO COAST TO A STOP. USE THE FOOT BRAKE TO STOP THE LATHE WHENEVER POSSIBLE.**

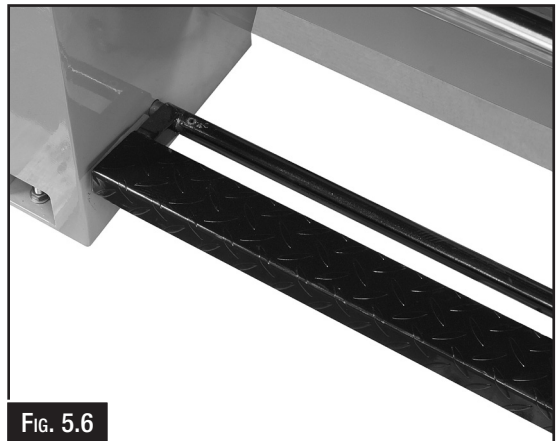

Fig. 5.6

### Slide Out Swarf Tray (Fig. 5.7)

The machine is fitted with a Slide out front swarf tray designed for easy cleaning.

 <b>WARNING!</b>	
	<p><b><i>Always use leather gloves when handling swarf. Cuttings are sharp and can cause deep cuts and other injuries.</i></b></p>



Fig. 5.7

**TAILSTOCK Fig. 5.8**

The tailstock has many functions. The main use is for holding drill chucks and centres.

The barrel has been etched with graduations in millimetres and inches and has a Morse taper #3 bore. The tailstock also can be offset to cut tapers.

- A. **Top Lock Lever** - This lever locks the tailstock barrel in place.
- B. **Side Lock Lever** - This lever locks the tailstock in place on the lathe bed.
- C. **Tailstock Hand-wheel** - Turning the hand-wheel advances or retracts the barrel in the tailstock. The graduated dial on the hand wheel is adjustable.
- D. **Tailstock Adjustment** - Two grub screws, (one either side) control the adjustment of the tailstock when taper turning is required.

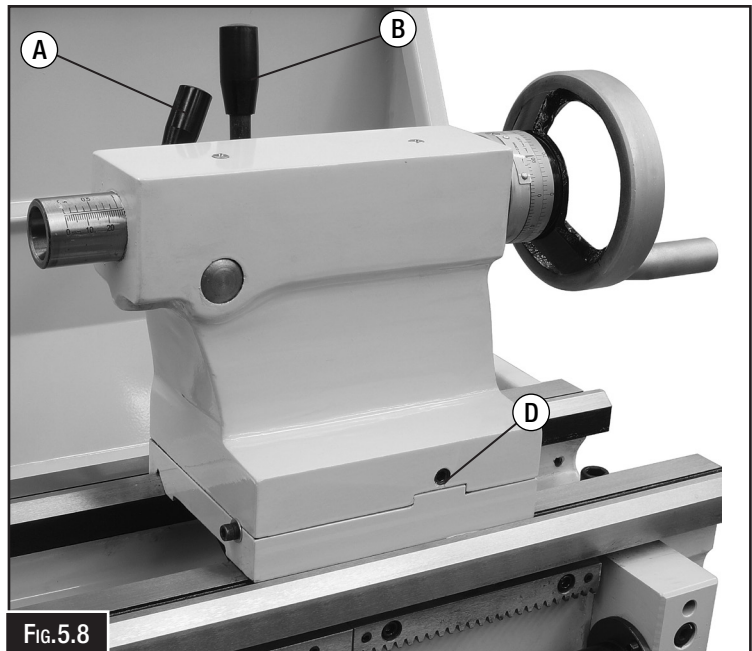

**STEADIES Fig. 5.9**

- E. **Knurled Screws** - Moves the fingers in or out to allow for adjustment.
- F. **Lock Nut** - When unlocked allows the fixed steady to be split to allow the steady to be placed around the work.

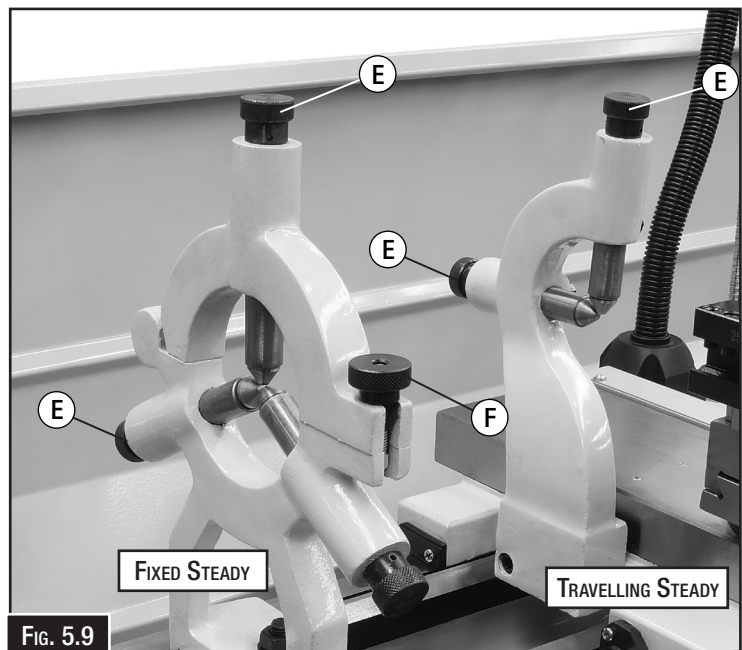

## 5.2 CHUCK & FACEPLATE MOUNTING

This lathe is equipped with a D1- 4 Camlock spindle nose. This type of spindle uses cams that are adjusted with a chuck key to securely mount a chuck or faceplate with repeatable precision and ease. Because chucks are heavy and often awkward to hold, some kind of lifting, support, or protective device should be used during installation or removal. (Fig. 5.10)

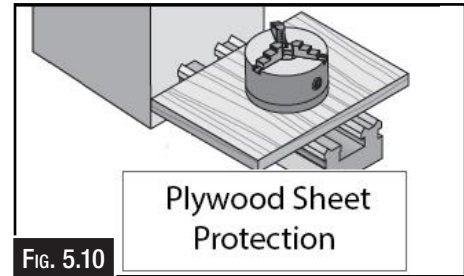

FIG. 5.10

To ensure that the work is accurate, it is extremely important to make sure the spindle nose and chuck mating surfaces and tapers are clean. Even a small amount of lint or dirt can affect the accuracy.

The chuck is properly installed when all camlocks are tight, the spindle and chuck tapers firmly lock together, and the back of the chuck is firmly seated against the face of the spindle all the way and without any gaps.

### Mounting The Chuck

Clean and lightly oil the camlock studs, then thoroughly clean the mating surfaces of the spindle and chuck.

Install the chuck by inserting the camlock studs straight into the spindle cam holes.

**NOTE: Avoid inserting the studs in from an angle or rotating the spindle. This can damage the studs or the cam holes. (Fig. 5.11)**

When the chuck is fully seated and all the camlocks are tight, check that the cam line is between the two "V" marks on the spindle nose, as shown in Fig. 5.12.

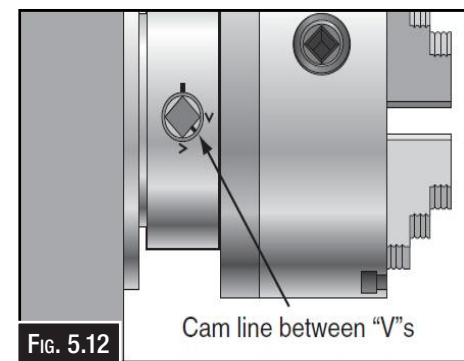
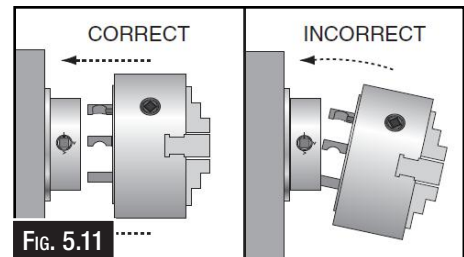

If the cam line is not between the "V" marks when the camlock is tight, the stud may be installed at the incorrect height.

First check that the line on the cam is flush with the surface of the chuck. If it is not then adjust the stud height as shown (Fig. 5.13).

Make sure to re-install the stud cap screw afterward.

If adjusting the stud height does not correct the problem, try swapping stud positions on the chuck.

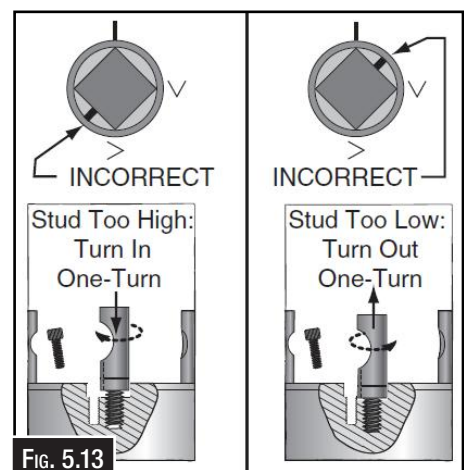

### Changing Jaws on 3 Jaw Chuck (Fig. 5.14)

Changing jaws on a lathe chuck is a task that requires some care and attention to ensure it is done safely and correctly. Here are general steps that can guide you through the process:

1. Before you start, make sure the lathe is turned off and unplugged. Wear appropriate personal protective equipment such as gloves and safety glasses.
2. Ensure you have the correct replacement jaws that are compatible with your lathe chuck.
3. Make sure that the chuck and the replacement jaws have been thoroughly cleaned.
4. Insert the chuck key into a scroll keyway and rotate it until the jaws are released from the chuck body.
5. Examine the side of the jaws-each is stamped with a number 1 through to 3.
6. Examine the jaw guides of the chuck. Each is stamped with a corresponding number.
7. Slide the #1 jaw into the #1 jaw guide and hold it firmly against the scroll gear threads, then rotate the chuck key clockwise approximately one turn until the lead thread engages with the jaw. (Fig. 5.14)

**NOTE: TUG ON THE JAW TO MAKE SURE IT IS ENGAGED WITH THE SCROLL GEAR THREAD.**

8. Repeat Steps 3-4 for jaws #2 and #3 in sequence.
9. Rotate the chuck key clockwise to bring the jaws together in the center of the chuck. If installed correctly, the jaws will converge evenly at the center of the chuck. If the jaws do not come together evenly, remove them, make sure the numbers of the jaws and the jaw guides match, then properly re-install them.

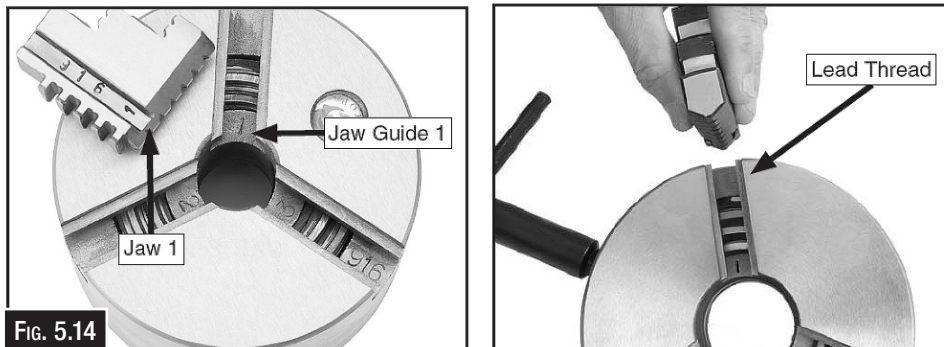

FIG. 5.14

### Faceplate Or 4 Jaw Chuck (Fig.5.15)

This section outlines basic operation safety related to using the faceplate included with your lathe. Use knowledge of safety and common sense when applying the steps on how to use this faceplate.

The faceplate is cast-iron and has multiple slots for T-bolts that hold clamping hardware. If you suspect that any of the chuck or jaw combinations may not hold a workpiece safely, remove the chuck and install the faceplate as outlined for special clamping options. However, just as with the 4-Jaw chuck, not all work pieces can be safely held. Holding a workpiece off center or holding an irregular shaped workpiece will cause the entire assembly to rotate out of balance.

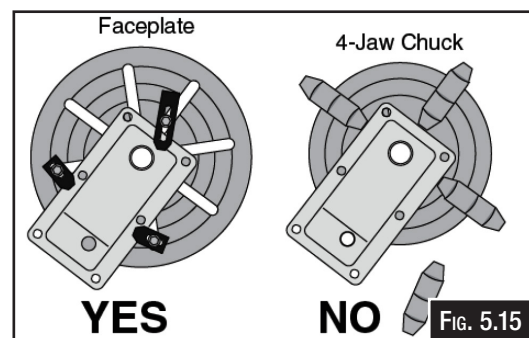

FIG. 5.15

If spun any speed too high, the workpiece can eject hitting the lathe operator or bystanders causing a severe or fatal injury. Fig. 5.15 shows an example of a workpiece being improperly held with the 4-jaw chuck. One jaw of the chuck interfered with the workpiece edge, and removing the jaw creates an extreme workpiece ejection hazard. The workpiece holding solution shown in Fig. 5.15 is to use the faceplate with a minimum of three clamps that are spaced as equally apart as possible for full support.

### 5.3 SETTING THE CUTTING TOOL ON THE CENTERLINE

The tip of the cutting tool should be set up so that it is in line with the centerline of the spindle, as illustrated in Fig. 5.16.

The cutting tool can be raised by placing steel shims underneath it. The shims should be as long and as wide as the cutting tool to properly support it.

There are a number of ways to check that the cutting tool is on the centre line of the spindle.

**Below are two common methods:**

1. Move the tailstock center over the cross slide and use a fine ruler to measure the distance from the surface of the cross slide to the tip of the center. Adjust the cutting tool height so it is the same distance above the cross slide as the tailstock center.
2. Align the tip of the cutting tool with a tail stock center, as described in the following procedure.(Fig. 5.17)
  - a. Mount the cutting tool and secure the post so the tool faces the tailstock.
  - b. Install a center in the tailstock, and position the tip near the cutting tool.
  - c. Lock the tailstock and quill in place.
  - d. Adjust the height of the cutting tool tip to meet the center tip, as shown. (Fig. 5.16)

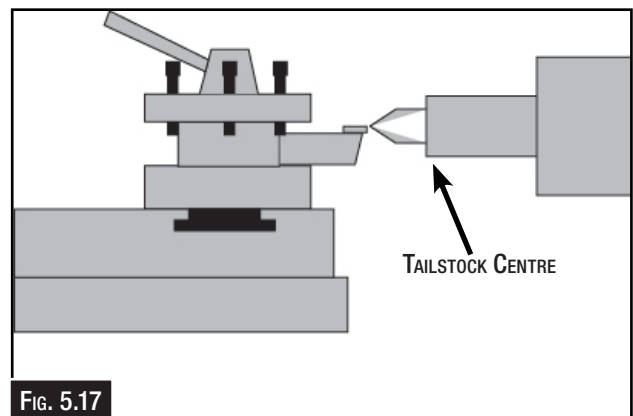
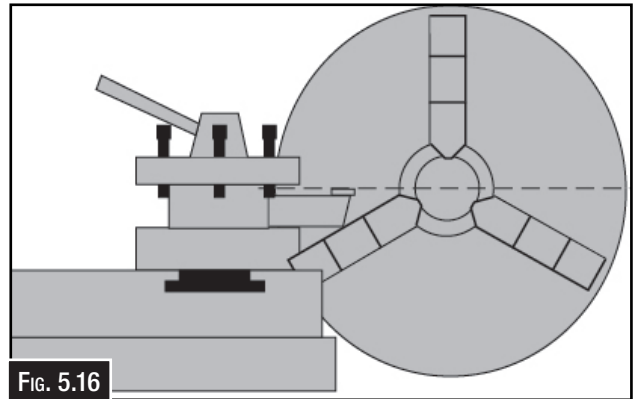

## WARNING

*The machine is the sole responsibility of the owner for its safe use. This responsibility includes but is not limited to proper installation in a safe environment, personnel training, proper inspection and maintenance, manual availability and comprehension. The manufacturer will not be held liable for injury or property damage from negligence, improper training, machine modifications or misuse.*

## 5.4 SPINDLE SPEEDS

Using the correct spindle speed is important for getting safe and satisfactory results, as well as maximizing tool life.

To set the spindle speed for your operation, you will need to:

- 1) Determine the best spindle speed for the cutting task,
- 2) Configure the lathe controls to produce the required spindle speed.

### Determining Spindle Speed

Many variables affect the optimum spindle speed to use for any given operation, but the two most important are the recommended cutting speed for the workpiece material and the diameter of the workpiece, as noted in the formula shown below.

$$\frac{\text{RECOMMENDED CUTTING SPEED (MTRS/MIN)} \times 1000}{\text{DIAMETER IN MILLIMETERS} \times 3.14} = \text{RPM}$$

The Fitting & Machining handbook (L341) and some Internet sites, provide excellent recommendations for which cutting speeds to use when calculating the spindle speed.

These sources also provide a wealth of additional information about the variables that affect cutting speed and they are a good educational resource.

### Example:

1. Set the High/Low lever. (A in Fig. 5.18)  
Low 70 - 440 rpm.  
High 350 - 2000 rpm.
2. Rotate the speed (C) dial until the speed is displayed on the digital readout. (B)

Note: If the spindle High or Low speed levers do not easily adjust into position, rotate the spindle by hand while you apply pressure to the lever. When the gears align, the lever will easily move into place. If you have trouble rotating the spindle by hand, you can use the spindle key or a chuck key to get additional leverage—just be sure to remove the key when you are done.



Fig. 5.18



### **WARNING.**

*To avoid damaging gears, ALWAYS make sure the spindle is completely stopped BEFORE moving the spindle speed levers.*

## 5.5 THREADING

The machine is designed to cut most metric and inch threads. The following sections will describe how to use the threading controls to set up the lathe for a threading operation. If you are unfamiliar with the process of cutting threads on a lathe, it is strongly recommend that you read a trade manual such as Hafco L341, or seek formal training before attempting any threading projects. Consult the thread charts for the correct lever settings.

ORDER CODE L341

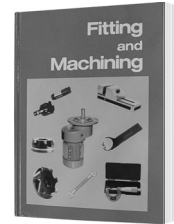

		n / 1"									mm											
		A2	A3	C3	A4	C3	C3	C3	A5	B4			B4	C4	C3	C2	A4	D2	E4	A2	E2	
	Z	24	24	38	24	22	24	26	24	24		MI	0.4	0.45	0.5		0.6		0.7	0.75		
	MII	4	4½	9½	5	5½	6	6½	7	7½		MII	0.8	0.9	1		1.2	1.25	1.4	1.5	1.75	
	MI	8	9	19	10	11	12	13	14	15		MI	1.6	1.8	2	2.25	2.4	2.5	2.8	3	3.5	
	Z1	48	48	38	48	44	48	52	48	48		MI	3.2	3.6	4	4.5	4.8	5	5.6	6	7	
	MII	16	18	19	20	22	24	26	28	30		MII	3.2	3.6	4	4.5	4.8	5	5.6	6	7	
	MI	32	36	38	40	44	48	52	56	60												

FIG.5.19

### Feed & Threading Gearbox

The setup procedure on this lathe is the same for metric & inch threads. These thread selections are indicated by a series of letters and numbers shown on the headstock threading charts. First, the change gear positions are checked and rearranged if indicated by the chart. Next, the quick change gearbox knobs and levers are moved to specific positions also indicated by the chart.

#### To set up for threading:

1. DISCONNECT LATHE FROM POWER!
2. Open the change gear door on the left hand side of the headstock to expose the change gears.
3. Review the threading chart for the required thread to be cut (Fig. 5.19). The chart indicates that to cut a 0.75 metric thread, the change gears and feed dials must be in the following positions.
4. Turn the first knob of the quick change gearbox to "2" position, turn the second knob to "M" position, turn the third knob to "A" position and turn the fourth knob to "I" position. (Fig. 5.20). Leaving 0.08mm–0.15mm backlash between gear teeth, arranges the 24 teeth change gear to 120 teeth and 120 teeth to 48 tooth change gear.
5. Rotate the spindle by hand to verify no binding exists, and close the gear door.



FIG. 5.20

### Leadscrew Direction

Selects the direction for lead screw and the power feed. (Fig. 5.21). When lever is positioned to the right side, the carriage will move to the left along the bed, or the cross feed will travel toward the front of the lathe.

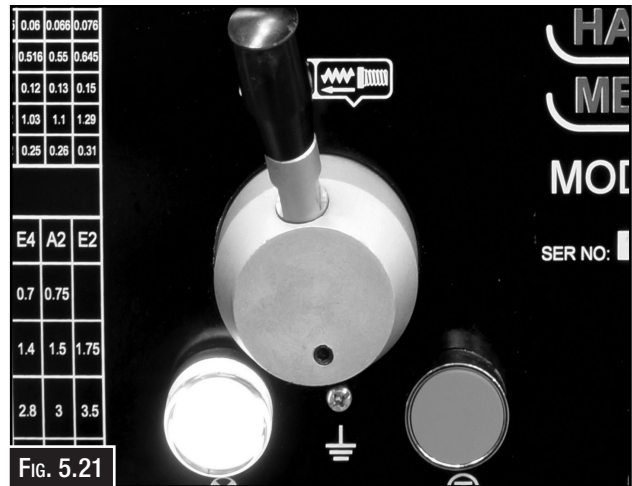

### Thread Chasing Dial

The numbers on the thread dial are used with the thread dial chart (Fig. 5.22) to show when to engage the half nut during metric threading. (Fig. 5.22)

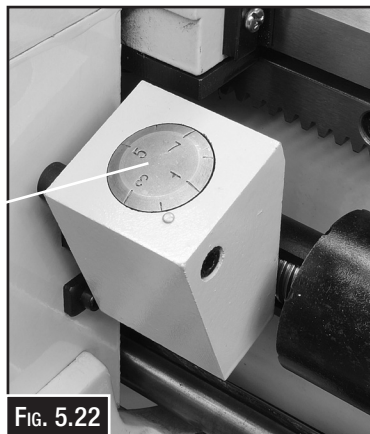
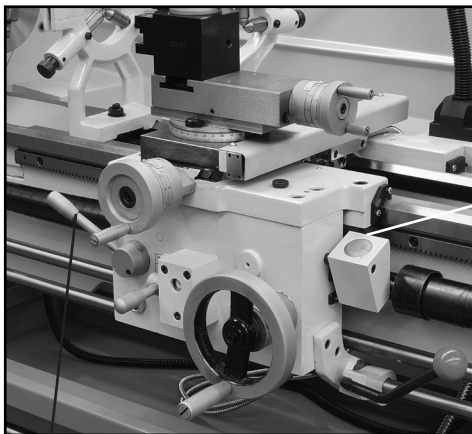
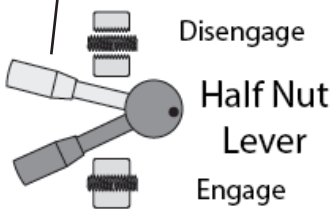

FIG. 5.22

mm			mm		
T	mm		T	mm	
0	0.5	/	15	0.45	1
	0.6	/		0.9	1
	0.75	/		1.25	1
	1	/		1.8	1
	1.5	/		2.25	1
	3	/		2.5	1
16	0.4	1-8	14	4.5	1
	0.8	1,3,5,7		5	1
	1.2	1-8		0.7	1.5
	1.6	1.5		1.4	1.5
	2	1-8		1.75	1.5
	2.4	1,3,5,7		2.8	1
	3.2	1		3.5	1.5
	4	1,3,5,7		7	1.5
	4.8	1.5			
	6	1-8			

FIG. 5.22



**NOTE:** When cutting inch threads, the thread dial must be disengaged from the leadscrew, and the half nut clamped to the leadscrew until the threads are complete. Otherwise the path of the same thread will be lost. All carriage returns for non-metric threads are made by backing the tool point out of the thread, and reversing spindle rotation with the spindle ON/OFF lever.

To engage the thread dial, loosen the mounting cap screw, then pivot the dial into the leadscrew so the gear teeth mesh with the leadscrew. Re-tighten the cap screw to hold the thread dial in place.

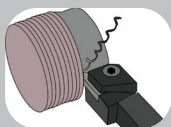

### **WARNING!**

**STOP** the machine before attempting to remove the swarf. Use leather gloves when handling swarf. Cuttings are sharp and can cause injury.

## 5.6 CHANGE GEARS

The end gears are used to setup for power feed, inch, or metric threading operations. See Fig. 5.23 to identify the upper gear, middle 120T/127T change gears, and the lower gear. Details on which gear to use are found on the headstock feed and threading charts.

### Change Gear Configuration

To configure the change gears:

1. Locate the chart on the headstock that has the thread or feed option that is required.
2. **DISCONNECT THE MACHINE FROM POWER!**
3. Remove the headstock end gear cover.
4. While holding the 120T/127T gears, loosen the arm by undoing the gear support hex nut and slowly let the gears pivot down and away from the upper top gear, as illustrated. (Fig. 5.24)
5. Loosen the 120T/127T gear hex nut and slide the middle gear away from the bottom gear. The 120T/127T gears many need to be reversed. Undo the 120T/127T gear hex nut (Fig. 5.25) and reverse the gears.
6. Remove the cap screw and flat washer from the top gear, then slide the gear off the shaft. Slide the desired gear onto the top gear shaft and desired gear onto the bottom gear shaft making sure to align the keys and keyways. Position the flat, non-stepped face of the gears away from the headstock so they will mesh with either the 120T or 127T gear depending on which one is required.
7. Secure the top and bottom gears with the flat washers and cap screws that were removed earlier.
8. Raise the gear support arm and mesh the top gear with the 120T/127T, then tighten the gear support hex nut and replace the change gear cover.

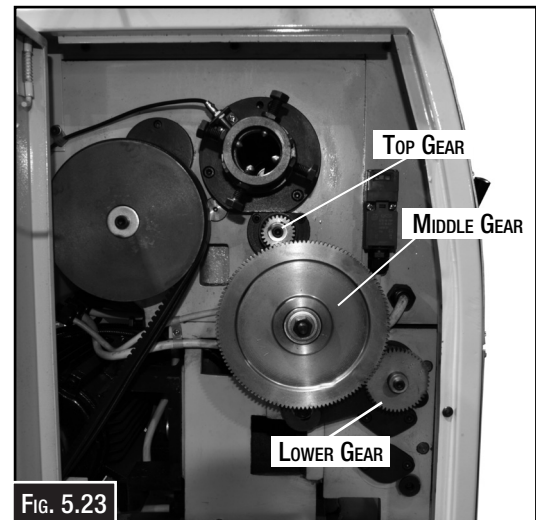

FIG. 5.23

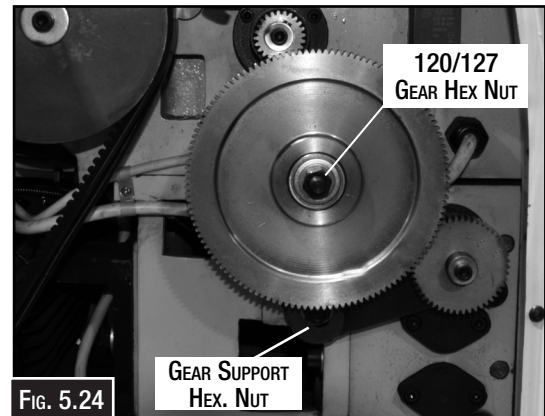

FIG. 5.24

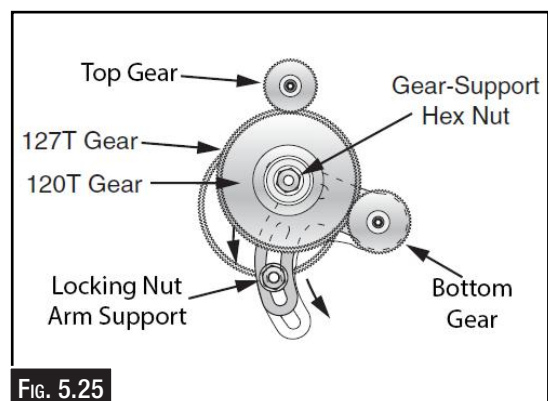
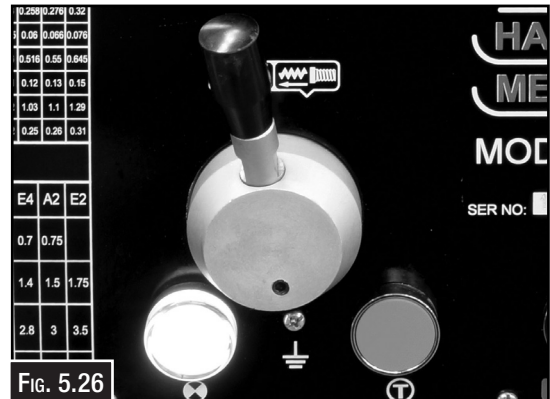

FIG. 5.25

## 5.7 SELECTING THE FEEDS

The AL-346V Metal Lathe can cut left or right while feeding or threading, and both ways for facing operations. This feed direction is controlled by the selection knob on the headstock (Fig.5.26)

**NOTE: The feed direction knob should not be changed while the spindle is rotating.**



### Selecting the Feed Rod

The feed rod can be selected by rotating the “S” or “M” Knob to the “S”. (Fig. 5.27). Use this position for all feeding operations. When the knob is positioned to “M”, threading selections can be made.



**Feed Lever** - Longitudinal and cross slide powered feeds are controlled by the feed lever. The lever pivots through two stops which require moving the lever left and right as well as up and down.

Moving this lever upward activates the automatic longitudinal feed. Moving the lever down activates the cross slide for facing operations. (Fig. 5.28)

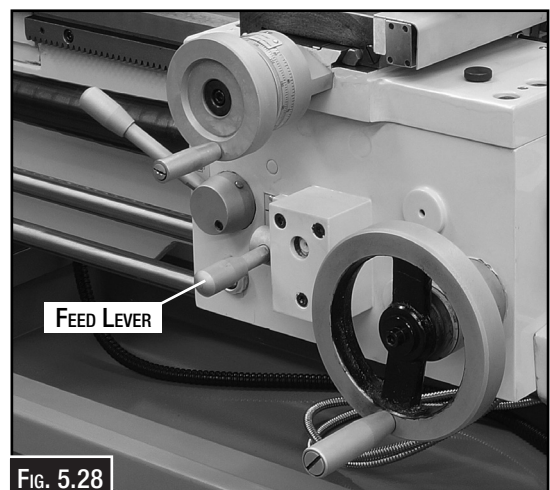
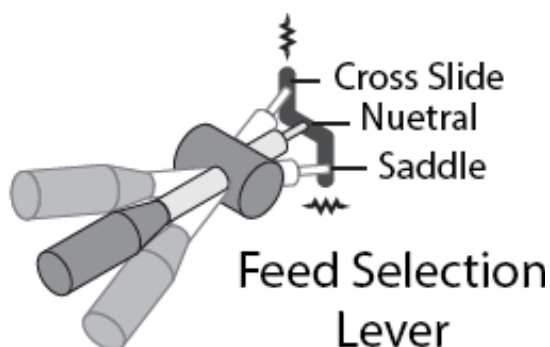

## 5.8 QUICK CHANGE TOOLPOST

The included tool post is a 250 series piston-type quick-change model. The quick-change lock lever allows for one or more tool holders to be quickly loaded and unloaded in two available dovetailed slots. By having extra tool holders and setting the tool height in advance, swapping between tooling is efficient for production sensitive schedules. When loosened, the mounting hex nut allows the entire tool post to rotate 360° for angle adjustments.

### To load a tool holder:

1. Install the required cutting tool in the tool holder.
2. Move the quick-change lever (Fig. 5.29) to recess the lock piston and provide an unobstructed slot for the tool holder to slide down into.
3. Slide the tool holder into position, and tighten the quick-change lever.
4. Use the handwheels to bring the tool to the required position.
5. Double check that tool angle, height, and position are correct.
6. Make sure that all fasteners related to the tool, holder, and tool post are tight.

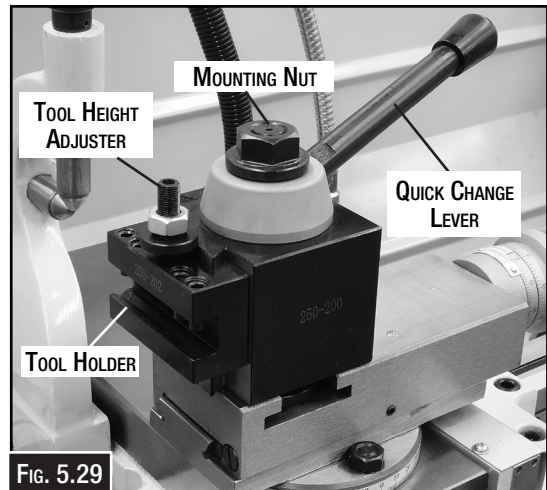

### OPTIONAL TOOLHOLDERS

**Standard Holder for Quick Change Toolpost**  
ORDER CODE L291A  
Suits 16mm Tool.



**Parting Holder for Quick Change Toolpost**  
ORDER CODE L291B  
Optional Accessory  
1/2" Part Off Blade - High Speed Steel Bit (L0007)



**Knurling Holder for Quick Change Toolpost**  
ORDER CODE L291C  
Cross Knurls



**Standard Holder for Quick Change Toolpost**  
ORDER CODE L292D  
Suits 20mm Tool



### WARNING!

*Before operating any machine, take time to read and understand all safety signs and symbols. If not understood seek explanation from trade magazines or an experienced operator.*

## 5.9 ALIGNING TAILSTOCK TO SPINDLE CENTERLINE

By offsetting the tailstock, the dead center can hold a workpiece off centre from the spindle centerline so tapers and pipe threads can be cut. An offset scale (Fig. 5.30) with increments is located at the rear of the tailstock. However, to achieve exact taper angles, or to adjust the tailstock back into the spindle centerline, angle gauges and a test indicator must be used.

### To offset the tailstock:

1. Loosen the tailstock lock lever.
2. Using a hex wrench loosen one of the front or rear adjustment screws shown in Fig. 5.30
  - To move the tailstock toward the rear of the lathe, loosen the rear adjustment screw and tighten the front screw.
  - To move the tailstock toward the front of the lathe, loosen the front adjustment screw and tighten the rear screw.
3. Apply the tailstock lock lever, and check the amount of the tailstock offset. Unlock and readjust as required for fine tuning.

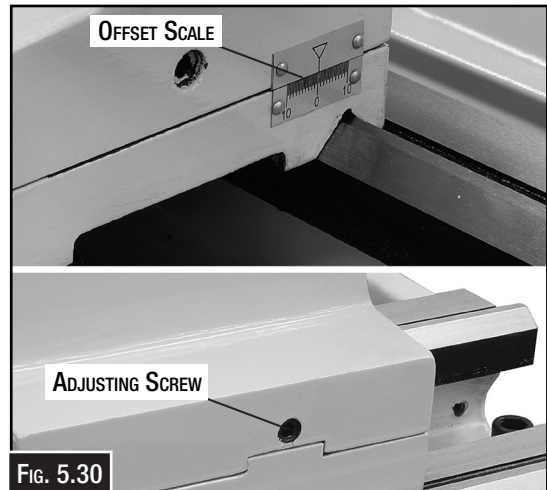

FIG. 5.30

### Aligning Tailstock

1. Center drill a 6" long piece of bar stock on both ends. Set it aside for use in Step 4.
2. Make a dead center by turning a shoulder to make a shank. Flip the piece over in the chuck and turn a 60° point (Fig. 5.31). As long as it remains in the chuck, the point of your center will be accurate to the spindle axis.
3. Place the live center in your tailstock.
4. Attach a lathe dog to the chuck bar stock from step 1, and mount between the centers (Fig. 5.32).
5. Turn approximately 0.25mm off the diameter.
6. Mount a dial indicator so that the plunger is on the tailstock quill (Fig. 5.25).
7. Measure the stock with a micrometer. if the stock is wider at the tailstock end, the tailstock needs to be moved toward the front of the lathe half the amount of the taper. If the stock is thinner, at the tailstock end, the tailstock needs to be moved toward the rear of the lathe by half the amount of the taper (Fig. 5.32)

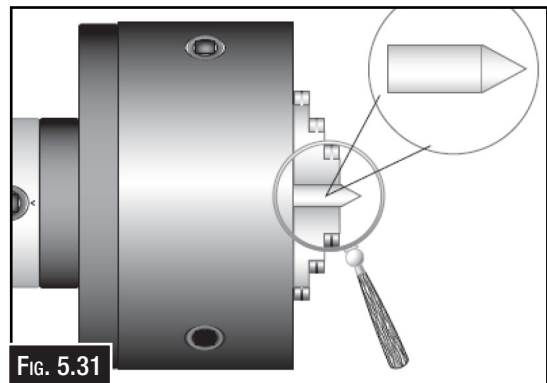

FIG. 5.31

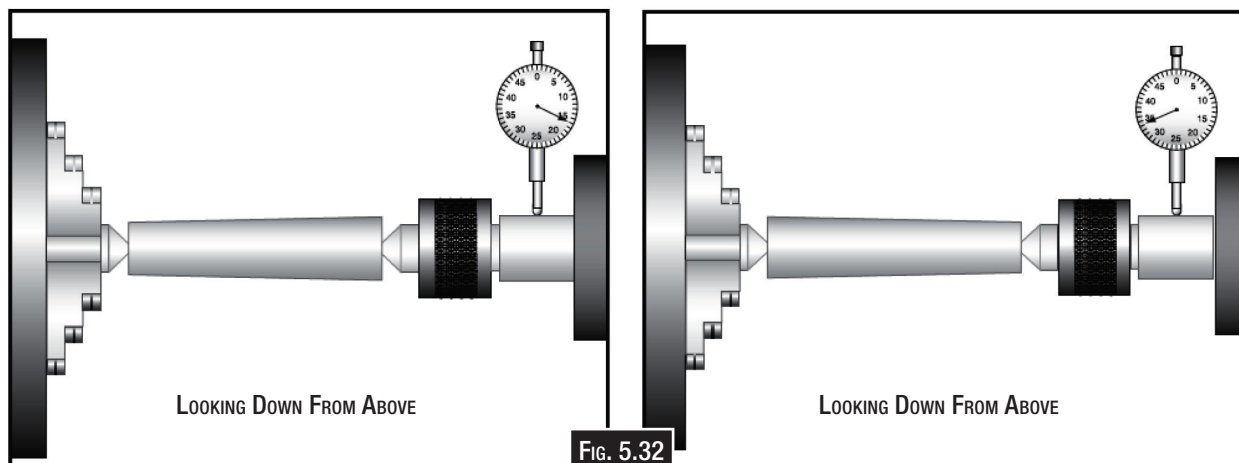

FIG. 5.32

## 5.10 REMOVING AND REPLACING THE BED GAP

This AL-346V Lathe bed is equipped with a removable gap that allows for the turning of large diameter workpieces. The gap was seated, pre-loaded, and then ground for precise mating and alignment at the factory.

Removing the gap can cause the lathe insert to slightly spring out of shape. When re-installed, there is no guarantee that original alignment and flush mating will be the same. For this reason, removing the gap is considered a permanent alteration to the lathe, even if it is later re-installed.

### To Remove The Gap

1. Disconnect lathe from power!
2. Loosen the preload set screw a few turns until it no longer contacts the headstock. (Fig. 5.33).
3. Tighten the dowel-pin jack nut to draw the pins from the gap.
4. Remove the four cap screws that secure the gap to the bed.
5. Tap the outside of the gap piece with a dead blow hammer to loosen it, and, with the help of another person, remove the gap piece.

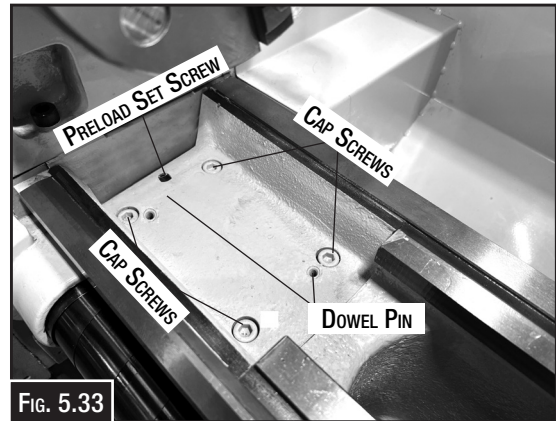

Fig. 5.33

### To Replace The Gap

1. Disconnect lathe from power!
2. Clean the mating surfaces.
3. Place the gap in the bed. Tap the dowel-pins in to align the gap.
4. Place the four cap screws that secure the gap to the bed.
5. Tighten the 4 screws and the preload screw.

<b>! WARNING</b>	
<b>SAFETY FIRST</b>	<p><i>The safety instructions given in this manual can not be complete. The environment in every shop is different. Always consider your safety first as it applies to your individual working conditions.</i></p>
<b>SAFETY FIRST</b>	

## 5.11 OPTIONAL TOOLING

Order Code	Description	
<b>L258</b>	<p><b>Taper Turning Attachment.</b> For turning tapers this will suit machines AL-346V centre lathes. It can be adapted to many other lathes as well.</p> <p><i>Please Note: Some modifications maybe required to fit taper turning attachment to these lathes.</i></p>	

5.11 OPTIONAL TOOLING Cont.

Order Code	Description	
L451	<p>For turning tools to suit this machine Hafco recommends <b>Toolmaster 16mm Turning and Boring Set.</b> 3 piece set complete with inserts that fit each toolholder and boring bar.</p>	
L457	<p>For threading tools to suit this machine Hafco recommends <b>Toolmaster 16mm Threading Tool Set.</b> 2 piece set complete with a 60 degree and 55 degree inserts that fit the toolholder and the boring bar.</p>	
C052	<p>For a Live Centre to suit this machine Hafco recommends <b>Hafco 3MT Live Centre.</b> Concentric within 0.01mm. Centre runs on taper roller bearing and needle roller bearing.</p>	
L076	<p>For Knurling Tool to suit this machine. Hafco recommends <b>Toolmaster Knurling Tool Holder Kit.</b> 3 head knurling kit consisting of - medium and fine diamond knurls, and one straight knurl.</p>	
Q111	<p>For Measuring Hafco recommends <b>Measumax 20-111 Metric Outside Micrometers - 3 Piece Set.</b> Carbide tipped anvils, Flatness 0.0008mm Micro-fine clear graduations on satin chrome finish.</p>	

## 5.12 COOLANT SYSTEM

The cutting fluid system delivers cutting fluid via a flexible distribution hose and nozzle. The cutting fluid pump turns ON and OFF with a switch located on the control panel. Fluid flow is controlled by a manual flow control valve. (Fig. 5.34)

**NOTE! RUNNING THE PUMP WITHOUT ADEQUATE CUTTING FLUID IN THE RESERVOIR MAY PERMANENTLY DAMAGE IT. THIS TYPE OF DAMAGE IS NOT COVERED BY THE WARRANTY. ALWAYS USE HIGH QUALITY CUTTING FLUID AND FOLLOW THE MANUFACTURER'S INSTRUCTIONS FOR DILUTING. FREQUENTLY CHECK THE CUTTING FLUID CONDITION AND CHANGE IT PROMPTLY WHEN IT BECOMES OVERLY DIRTY OR RANCID.**

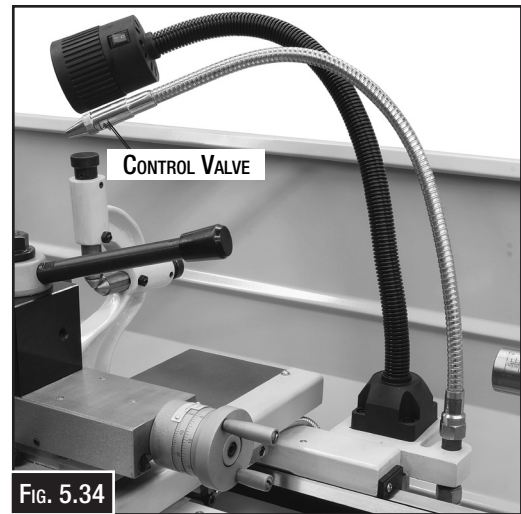

**WARNING! BIOLOGICAL AND POISON HAZARD! USE THE CORRECT PERSONAL PROTECTION EQUIPMENT WHEN HANDLING CUTTING FLUID AND BY FLUID MANUFACTURER REQUIREMENTS TO PROPERLY DISPOSE OF CUTTING FLUID.**

### Checking cutting fluid system

When checking the cutting fluid system, the goal is to make sure there is enough cutting fluid, the chip level in the first chamber is not too high, and the cutting fluid has not become rancid or contaminated.

#### To Check The Cutting Fluid System:

1. Disconnect lathe from power!
2. At the tailstock end of the lathe, remove the pump access cover.
3. Inspect the level of cutting fluid inside the tank. The cutting fluid should be approximately 25mm below the top of the tank.
4. Using a wooden stick, check the level of the metal chips in the first chamber (Fig. 5.35). If the chips are 3/4 the height of the baffle, then remove the chips.
5. Inspect the cutting fluid quality as outlined by the fluid manufacturer and replace as recommended.

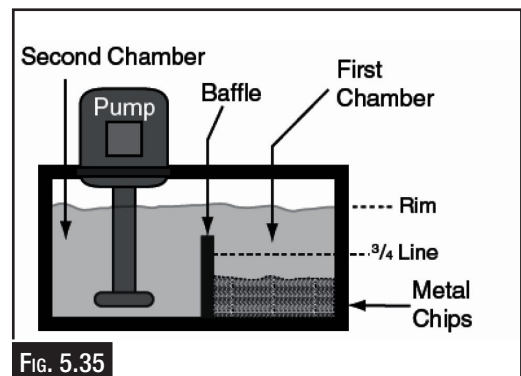

### Cleaning Cutting Fluid System

1. Place the drain hose on the end of the coolant nozzle, and pump the used cutting fluid into the drain bucket. As soon as pumping is complete turn OFF pump immediately.
2. Disconnect lathe from power!
3. Lift the tank assembly from the lathe stand.
4. Remove all metal shavings, any remaining cutting fluid, and clean out the tank.
5. Clean the intake screen on the pump.
6. Reinstall the cutting fluid tank into the lathe stand.
7. Mix the cutting fluid to the manufacturer's required specification , and fill the cutting fluid tank
8. Reinstall the pump access cover.

## 6. MAINTENANCE

### 6.1 LUBRICATION



#### **WARNING**

*Before maintaining or cleaning the machine, turn off the circuit breaker, or disconnect the machine from the power supply.*

*Post a sign to inform other workers that the machine is under maintenance.*

For optimum performance from the machine, it is important that the machine is well lubricated and maintained. Follow the maintenance schedule listed in the following section and refer to any specific instructions given.

**Use the information in the charts below as a daily guide for lubrication tasks**

Assembly	Part	Method	Lubricant	Interval
Headstock	Spindle Gears and Bearings	Oil Bath	Machine Oil	6 Months
Feed Box	Gears and Bearings	Oil Bath	Machine Oil	Check site glass daily and fill as required
Carriage	Gears and Bearings	Oil Bath	Machine Oil	Check site glass daily and fill as required
End Gears	Change gears and quadrant	Oil Can	Machine Oil and Grease	Once per shift
Carriage Slide	Bedway slides	Oil Can	Machine Oil	Once per shift
Cross Slide	Slides and Screws	Oil Can	Machine Oil	Once per shift
Tailstock	Quill and Screw	Oil Can	Machine Oil	Once per shift
Feed Screw	Screws and Bearings	Oil Can	Machine Oil	Once per shift
Lead Screw	Screw	Oil Can	Machine Oil	Annually

## 6.2 LUBRICATION POINTS

### Headstock

The headstock reservoir has the proper amount of oil when the oil level in the sight glass is approximately halfway. (Fig. 6.1) The oil sight glass is located below the chuck, The oil should be changed every six months by firstly draining the oil by removing the drain plug (Fig. 6.2) then filling by the oil filler plug. (Fig. 6.3)

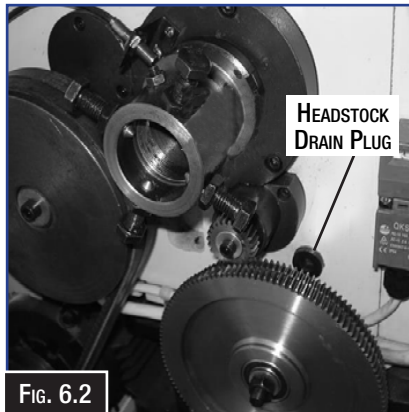
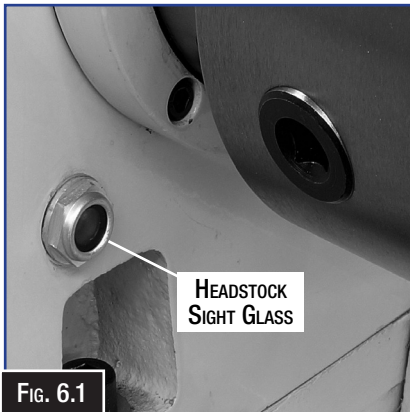

### APRON

The apron oil sight glass is on the front of the apron, as shown in Fig. 6.4. Maintain the oil volume so that the level is approximately halfway in the sight glass.

### Changing Oil & Flushing Reservoir

Small metal particles may accumulate at the bottom of the reservoir with normal use. Therefore, to keep the reservoir clean, drain and flush it at least once a year. Place a catch pan under the apron drain plug (Fig. 6.4), remove the fill plug, then use a 6mm hex wrench to remove the drain plug and empty the reservoir.

Flush the reservoir by pouring a small amount of clean oil into the fill hole and allowing it to drain out the bottom.

Replace the drain plug, add oil as required, then re-install the fill plug.

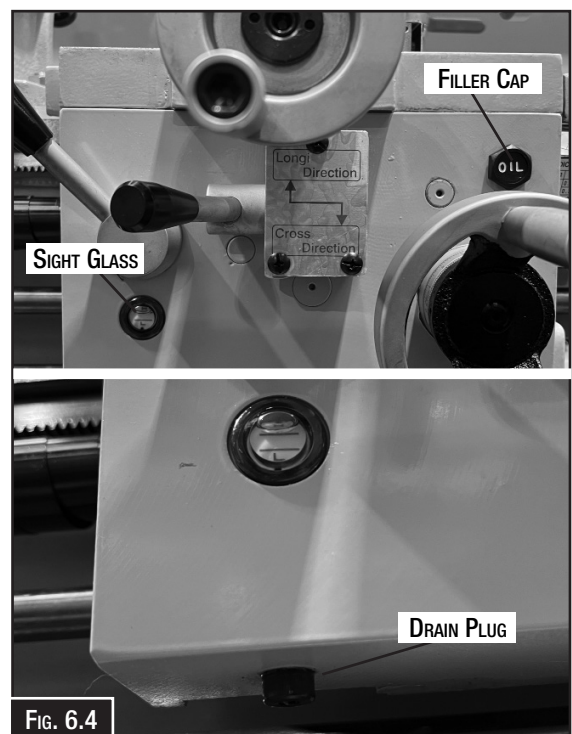

## Gearbox

The quick change gearbox has an oil reservoir that is equipped with a sight glass for the quick checking of the oil level. Before and after every use, make sure that the oil level is correct. Figures 6.5 and 6.6 show the gearbox locations of the sight glasses and the fill/drain plugs.



FIG. 6.5

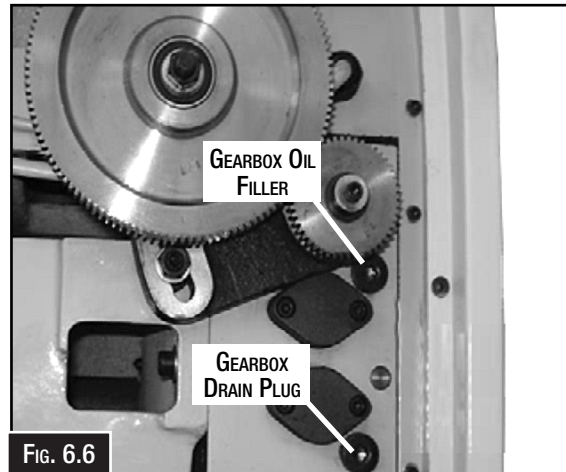

FIG. 6.6

To add oil to the reservoir:

1. Clean the area around the fill plug to prevent debris from falling in the reservoir when adding oil.
2. Remove the fill plug.
3. Slowly add oil until the oil level is centered in the sight glass.
4. Replace fill plug.

## Changing oil

The oil in the reservoirs must be changed after the first three months of operation, then twice a year after that. If the lathe is under heavy use, more frequent oil changes will be required to keep the gearboxes clean and ensure long machine life. Some lathe owners believe that by using full synthetic oils in the gearboxes is a way to extend oil change intervals. We do not recommend this practice. While synthetic oils are superior this lathe does not use a filter to remove contaminants that are generated during normal use, such as when shifting gears. Changing the oils on a frequent basis to flush out moisture and contaminants is still the best option to ensure long gearbox life.



## **CAUTION**

***Before attempting this feature, disconnect the machine from the power supply to avoid injury to the operator from accidental start-up or damage to the machine.***

## Longitudinal Leadscrew

Undo the end of the lead screw cover and slide it to the end of the shaft. Before lubricating the lead screw (Fig. 6.7) it should be cleaned with mineral spirits. The use of a stiff brush will help clean out the threads. Move the carriage out of the way, so you can clean the entire length of the lead screw. Apply a thin coat of oil along the length of the lead screw. Use a stiff brush to make sure the oil is applied evenly and down into the threads.

Replace the lead screw cover.

Lead Screw & Feed Shaft Bearings (Fig. 6.8) The feed and leads screw bearings are lubricated through ball oilers at the end of the bed. Lubricate with machine oil and check each shift.

## Ball Oilers (Fig. 6.9)

Proper lubrication of ball oilers is done with a pump-type oil can that has a plastic or rubberized cone tip, usually supplied with the accessories.

Lubricate the ball oilers before and after machine use, and more frequently under heavy use. When lubricating ball oilers, first clean the outside surface to remove any dust or grime. Push the tip of the oil can nozzle against the ball oiler to create a hydraulic seal, then pump the oil can once or twice. It is important not to press the ball oiler too hard with nozzle of the oil can as it may cause the ball to jam in the open position, allowing dirt to enter. If you see sludge and dirt coming out of the lubrication area, keep pumping the oil can until the oil runs clear. When finished, wipe away any excess oil.

Oilers can be found below

- Cross-slide leadscrew & slides.
- Compound-rest leadscrew & slides.
- Saddle slides.
- Carriage handwheel.
- Feed selection lever gearing.
- Tailstock ball oilers.
- Leadscrew end bearing.
- Feed rod end bearing.

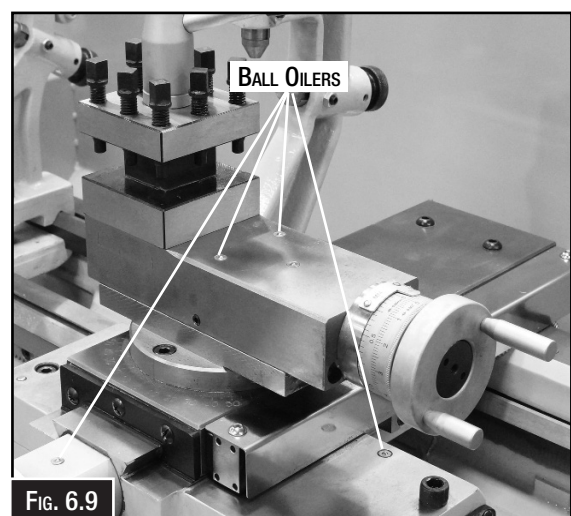
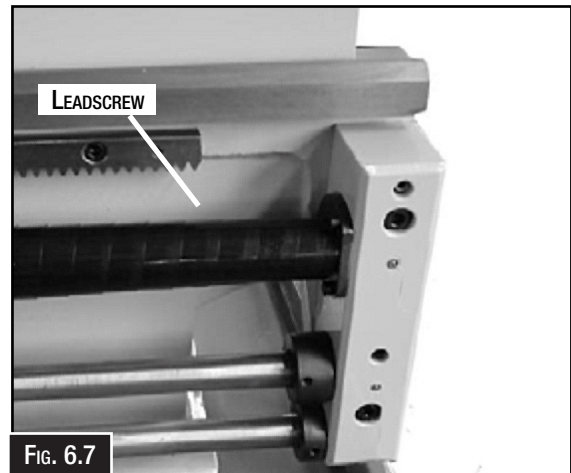

### 6.3 TROUBLESHOOTING

Review the troubleshooting and procedures in this section if a problem develops with your machine. If you need replacement parts then follow the procedure in the beginning of the spare parts section or if additional help with a procedure is required, then contact your distributor.

**Note: Make sure you have the model of the machine, serial number, and manufacture date before calling.**

Symptoms	Possible Cause	Possible Solution
Motor will not start.	<ol style="list-style-type: none"> <li>1. Stop button not reset.</li> <li>2. Main power panel switch is OFF.</li> <li>3. Circuit breaker or fuse has tripped.</li> <li>4. No voltage or open connection.</li> <li>5. Faulty capacitor.</li> <li>6. Spindle ON/OFF switch is at fault.</li> <li>7. Power switch or magnetic contactors faulty.</li> <li>8. Faulty Motor.</li> </ol>	<ol style="list-style-type: none"> <li>1. Reset the stop button.</li> <li>2. Turn the main power panel switch ON.</li> <li>3. Seek an electrician to trouble shoot and repair.</li> <li>4. Test circuit and connections as required.</li> <li>5. Replace capacitor.</li> <li>6. Replace switch.</li> <li>7. Replace power switch or magnetic cont-actor.</li> <li>8. Replace motor.</li> </ol>
Fuses or circuit breakers trip open.	<ol style="list-style-type: none"> <li>1. Short circuit in power lead or plug.</li> <li>2. Short circuit in motor or loose connections.</li> <li>3. Incorrect fuse or circuit breakers in power supply.</li> </ol>	<ol style="list-style-type: none"> <li>1. Inspect cord or plug for damage, repair or replace.</li> <li>2. Inspect all connections on motor. Repair as required.</li> <li>3. Install correct fuses or circuit breakers.</li> </ol>
Machine is loud, belt slips when cutting. Overheats or bogs down in the cut.	<ol style="list-style-type: none"> <li>1. Excessive depth of cut.</li> <li>2. RPM or feed rate wrong for operation.</li> <li>3. Dull cutting bit.</li> <li>4. Belt is slipping.</li> <li>5. Belt is at fault.</li> </ol>	<ol style="list-style-type: none"> <li>1. Decrease depth of cut.</li> <li>2. Refer to RPM feed rate chart for appropriate Speed or feed.</li> <li>3. Sharpen or replace cutting bit.</li> <li>4. Remove grease or oil from belt. Adjust belts.</li> <li>5. Replace belts.</li> </ol>
Gear change lever will not shift in position.	<ol style="list-style-type: none"> <li>1. Gears not aligned in the headstock.</li> </ol>	<ol style="list-style-type: none"> <li>1. Rotate the spindle by hand until the gear falls into place.</li> </ol>
Loud noise coming from machine at the rear near motor.	<ol style="list-style-type: none"> <li>1. Pulley set screw or keys are missing or loose.</li> </ol>	<ol style="list-style-type: none"> <li>1. Inspect keys and set screws. Replace or tighten if required.</li> </ol>
Entire Machine vibrates excessively upon start-up or while running.	<ol style="list-style-type: none"> <li>1. Workpiece is unbalanced.</li> <li>2. Worn or broken gear present.</li> <li>3. Chuck or faceplate has become unbalanced.</li> <li>4. Spindle bearings at fault.</li> </ol>	<ol style="list-style-type: none"> <li>1. Reinstall work piece so it is as centred with spindle centreline.</li> <li>2. Inspect gears and replace if required.</li> <li>3. Rebalance chuck or faceplate. Contact a machine shop for help.</li> <li>4. Adjust or replace spindle bearings.</li> </ol>
Cutting tool or machine components vibrate excessively during machining.	<ol style="list-style-type: none"> <li>1. Tool holder not tight enough.</li> <li>2. Cutting tool stick out too far out of the tool holder. Lack of support.</li> <li>3. Gibbs out of adjustment.</li> <li>4. Dull cutting tool.</li> <li>5. Incorrect spindle speed or feed rate.</li> </ol>	<ol style="list-style-type: none"> <li>1. Check for debris, clean and re tighten.</li> <li>2. Reinstall cutting tool so that no more than 1/3 of the total length is sticking out of the toolholder.</li> <li>3. Tighten gib screws on effected slide.</li> <li>4. Replace or sharpen the cutting tool.</li> <li>5. Use the recommended speed and feeds.</li> </ol>
Can't Remove the tapered tool from the tailstock quill.	<ol style="list-style-type: none"> <li>1. Quill has not retracted all the way back into the tailstock.</li> <li>2. Debris is binding arbor in the quill.</li> <li>3. Incorrect arbor or tooling inserted into the quill.</li> </ol>	<ol style="list-style-type: none"> <li>1. Turn the quill handwheel until it forces the taper out of the quill.</li> <li>2. Extend quill to exposed drift slot and use drift key to remove arbor.</li> <li>3. Remove quill and drive out tooling or arbor with punch.</li> </ol>
Cross slide, compound rest or carriage feed have sloppy operation.	<ol style="list-style-type: none"> <li>1. Gibbs out of adjustment.</li> <li>2. Handwheel is loose or has excessive backlash.</li> <li>3. Leadscrew mechanism worn out or out of adjustment.</li> </ol>	<ol style="list-style-type: none"> <li>1. Tighten gibs.</li> <li>2. Tighten screws and adjust backlash.</li> <li>3. Tighten any loose fasteners or leadscrew mechanism.</li> </ol>
Bad surface finish.	<ol style="list-style-type: none"> <li>1. Wrong RPM or feed rate.</li> <li>2. Dull tooling or poor tool selection.</li> <li>3. Too much play in the gibs.</li> <li>4. Tool too high.</li> </ol>	<ol style="list-style-type: none"> <li>1. Adjust to the appropriate RPM or feed rate.</li> <li>2. Sharpen tooling or select a better to for the operation.</li> <li>3. Tighten gibs.</li> <li>4. Lower the tool position.</li> </ol>

### 6.3 TROUBLESHOOTING Cont.

Symptoms	Possible Cause	Possible Solution
Inaccurate turning results from one end to the other end of the work-piece.	<ol style="list-style-type: none"> <li>1. Head stock and tailstock are not properly aligned.</li> <li>2. Head stock not aligned to the bed.</li> </ol>	<ol style="list-style-type: none"> <li>1. Realign the tailstock to the headstock spindle, bore and centre line.</li> <li>2. Contact you Hafco Metalmaster service centre.</li> </ol>
Chuck jaws won't move or do not move easily.	<ol style="list-style-type: none"> <li>1. Chips lodged in the jaws.</li> <li>2. Chuck Scroll binding.</li> </ol>	<ol style="list-style-type: none"> <li>1. Remove jaws and clean and lubricate chuck threads and replace jaws.</li> <li>2. Remove the chuck and dismantle. Clean with kerosene lubricate and re assemble.</li> </ol>
Carriage won't auto feed or overloads the spindle motor.	<ol style="list-style-type: none"> <li>1. Carriage or gib lock is applied.</li> <li>2. Gears are not all en-gauged or broken.</li> <li>3. Gibbs are too tight.</li> <li>4. Leadscrew shear pin has sheared.</li> </ol>	<ol style="list-style-type: none"> <li>1. Release locks.</li> <li>2. Adjust gear positions or replace.</li> <li>3. Loosen gib screws lightly.</li> <li>4. Correct the cause of the shear pin breakage and replace shear pin.</li> </ol>
Tail stock quill will not feed out	<ol style="list-style-type: none"> <li>1. Quill lock lever is tightened down</li> </ol>	<ol style="list-style-type: none"> <li>1. Turn lever counter clockwise.</li> </ol>

### 6.4 ADJUSTMENTS

#### Tapered Gib Adjustment

Tapered gibs are fitted to the slide ways of the saddle, cross-slide and top (compound) slides so that if any slackness, that may develop can be reduced. Make sure that slide ways are thoroughly cleaned and lubricated before attempting adjustment.

#### To adjust the top slide gib:

1. DISCONNECT MACHINE FROM POWER.
2. Release the rear gib screw and tightening the front screw a little at a time. Check constantly for a smooth action throughout the full slide travel. (Fig. 6.10)

#### To adjust the cross slide gib:

1. DISCONNECT MACHINE FROM POWER.
2. Undo the three button head screws that hold the slide wiper and remove the rubber wiper.
3. Release the rear gib screw and tightening the front screw a little at a time. Check constantly for a smooth action throughout the full slide travel.

#### To adjust the saddle slide gib:

1. Loosen the jam nuts on the four set screws (Fig. 6.11), and adjust the set screws.
2. Repeat adjustments as necessary until the carriage adjustment is acceptable.
6. Hold the set screws in place and tighten the jam nuts.

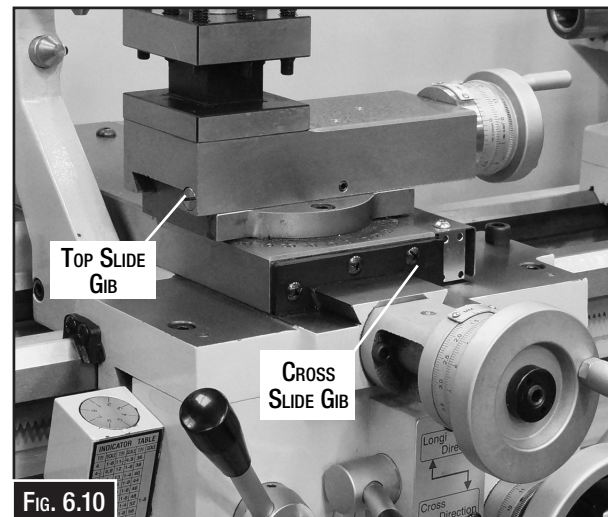

FIG. 6.10

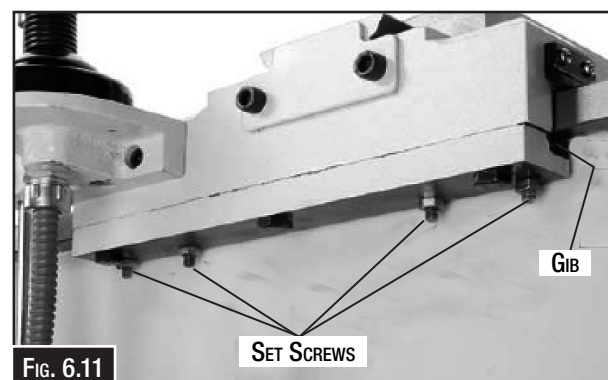

FIG. 6.11

**NOTE: Avoid over adjustment, which can result in an increased wear rate and stiff or jerky action of the movement.**

### Cross Slide Nut Adjustment.

This is an adjustment that can be made to eliminate excessive backlash, which may develop over time. Backlash is reduced through the cap head screw located at the rear of the nut.

#### To adjust the backlash:

1. DISCONNECT THE MACHINE FROM THE POWER SUPPLY
2. Remove the back splash guard.
3. With a long hex key in the cap head screw, make only small adjustment. Operating the cross slide several times by hand to be sure of smooth operation throughout the travel. (Fig. 6.12)

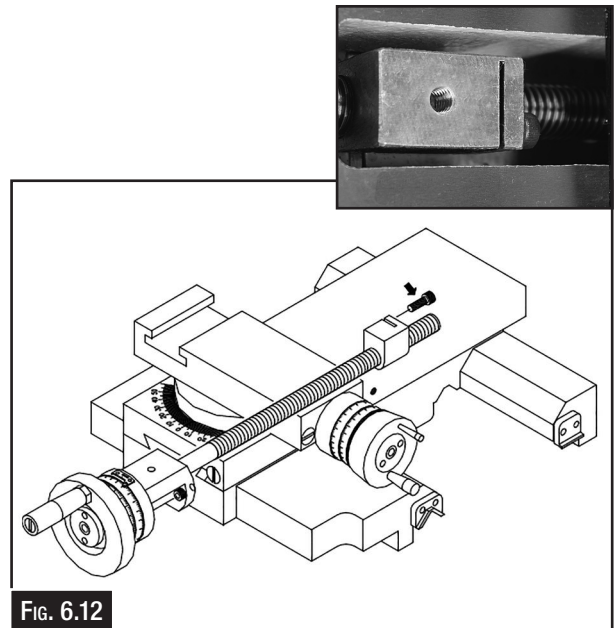

FIG. 6.12

### Feed clutch adjustment

This lathe is equipped with a feed rod clutch, shown in Fig. 6.13, that connects the feed drive hub with the feed rod through a set of spring-loaded internal balls. This clutch helps protect the apron feed system from overload. The feed rod clutch comes set from the factory, and should need no adjustment.

The clutch may slip if the path for the carriage or the cross feed is obstructed during turning or facing operations, the tool bit crashes into a workpiece shoulder, or if the carriage lock is left applied.

It is important to recognize, the clutch is not a foolproof way to protecting the lathe from damage if an operational mistake is made. Never completely tighten the feed clutch set screw past its normal setting outlined in this procedure in an attempt to completely eliminate clutch slip. Doing so will void the warranty, and can lead to catastrophic gearbox damage.

#### To adjust the feed rod clutch:

DISCONNECT LATHE FROM POWER!

—if the clutch slips during normal work loads and no problem exists with the feed system, the clutch spring pressure must be increased. Tighten the two set screws 1/8-turn and recheck for slippage.

—if for any reason the clutch is bound up or locked, and does not slip when it should, the clutch spring pressure must be reduced. Loosen the two set screws 1/8-turn, and recheck for slippage.

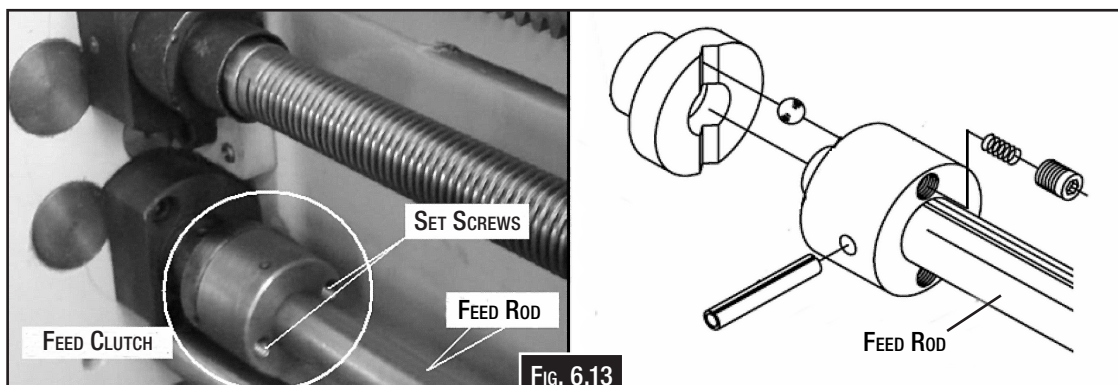

FIG. 6.13

## V-Belt Tension

After initial break in, the v-belts slightly stretch and seat into the pulley. It is important to check and adjust them to compensate for this initial wear. Check the tension thereafter on a monthly basis.

### To check the v-belt tension:

1. Disconnect lathe from power!
2. Open the headstock gear door.
3. Push the center of the v-belts with moderate pressure. The V-belt deflection should be approximately 10mm.  
—if the belt deflection is greater than 10mm, use the wrench to loosen the motor mount bolts (Fig. 6.14) and slide the motor downward until the deflection is correct.
4. Tighten the bolts and recheck the belts.

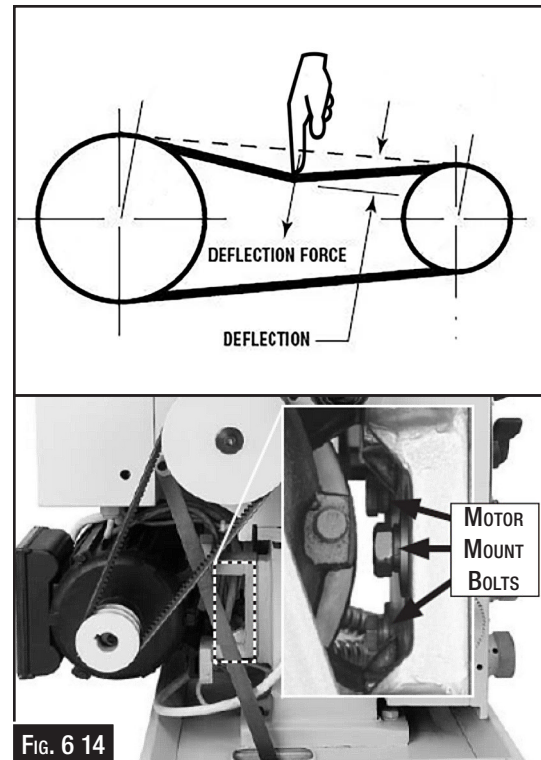

## Half Nut Adjustment

If the half-nut mechanism wears it may have to be adjusted if it becomes loose. The half nut is mounted in ways with a gib exerting pressure between components to reduce sloppy movement. The half-nut gib is a flat bar-type gib, similar to the saddle gib, and is tensioned with three set screws.

### To adjust the half nut:

1. DISCONNECT LATHE FROM POWER!
2. Open the half nut and remove the thread dial.
3. Loosen the hex nuts on the set screws shown in Fig. 6.15.
4. Tighten each set screw approximately 1/8 of a turn, then re-tighten the hex nuts without moving the set screws.
5. Move the carriage hand-wheel until the half nut can fully close, then open/close the half nut several times and notice how it feels. The half nut is correctly adjusted when you feel a slight drag while opening and closing. It should not feel stiff or loose.

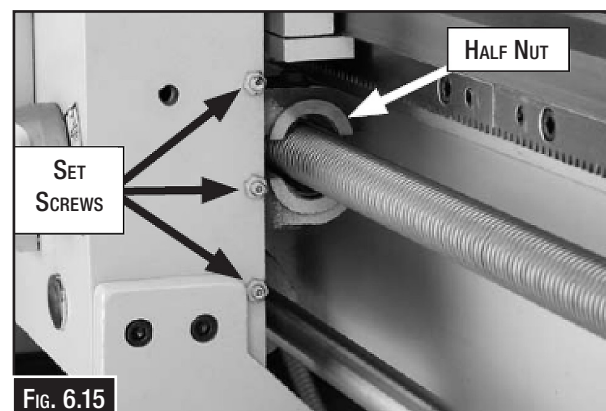

## **CENTRE LATHE AL-346V**

Order Code: (L555D)

Edition : 1.0  
Date: (07/25)

The following section covers the spare parts diagrams and lists that were current at the time this manual was originally printed. Due to continuous improvements of the machine, changes may be made at anytime without notification.

### **HOW TO ORDER SPARE PARTS**

1. Have your machines model number, serial number & date of manufacture on hand, these can be found on the specification plate mounted on the machine.
2. A scanned copy of your parts list/diagram with required spare part/s identified.

### **NOTE: SOME PARTS MAY ONLY BE AVAILABLE AS AN ASSEMBLY**

3. Go to [www.machineryhouse.com.au/contactus](http://www.machineryhouse.com.au/contactus) and fill out the inquiry form attaching a copy of scanned parts list.



### **WARNING!**

*Electricity is dangerous and could cause death  
All electrical work must be carried out by a qualified electrician.*



### **CAUTION!**

*It is impossible to cover all possible hazards Every workshop environment is different. These are designed as a guide to be used to compliment training and as a reminder to users prior to equipment use. Always consider safety first, as it applies to the individual working conditions.*

BED ASSEMBLY - DIAGRAM

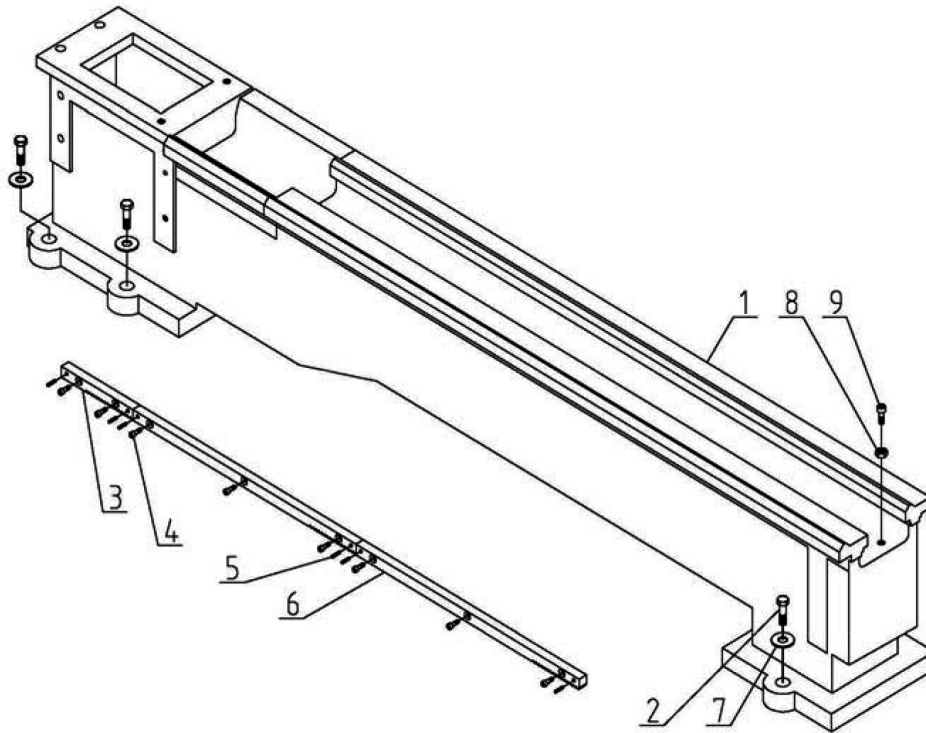

BED ASSEMBLY - PARTS LIST

Index No.	Part No.	Description	Size	Qty
1	D330AV-11101	LATHE BED		1
2	GB/T5782-M12X40	SCREW	M12X40	6
3	D330A-11205	RACK GEAR		1
4	GB/T70-M6X15	HEX SOCKET CAP SCREW	M6X15	8
5	GB/T879-6X25	PIN	6X25	6
6	D330A-11204	RACK GEAR		2
7	GB/T97.1-12	WASHER	12	6
8	GB/T6170-M10	NUT	M10	1
9	GB/T70-M10X35	HEX SOCKET CAP SCREW	M10X35	1

**NOTE: SOME INDIVIDUAL PARTS MAY ONLY BE AVAILABLE AS AN ASSEMBLY**

HEADSTOCK 1 - DIAGRAM

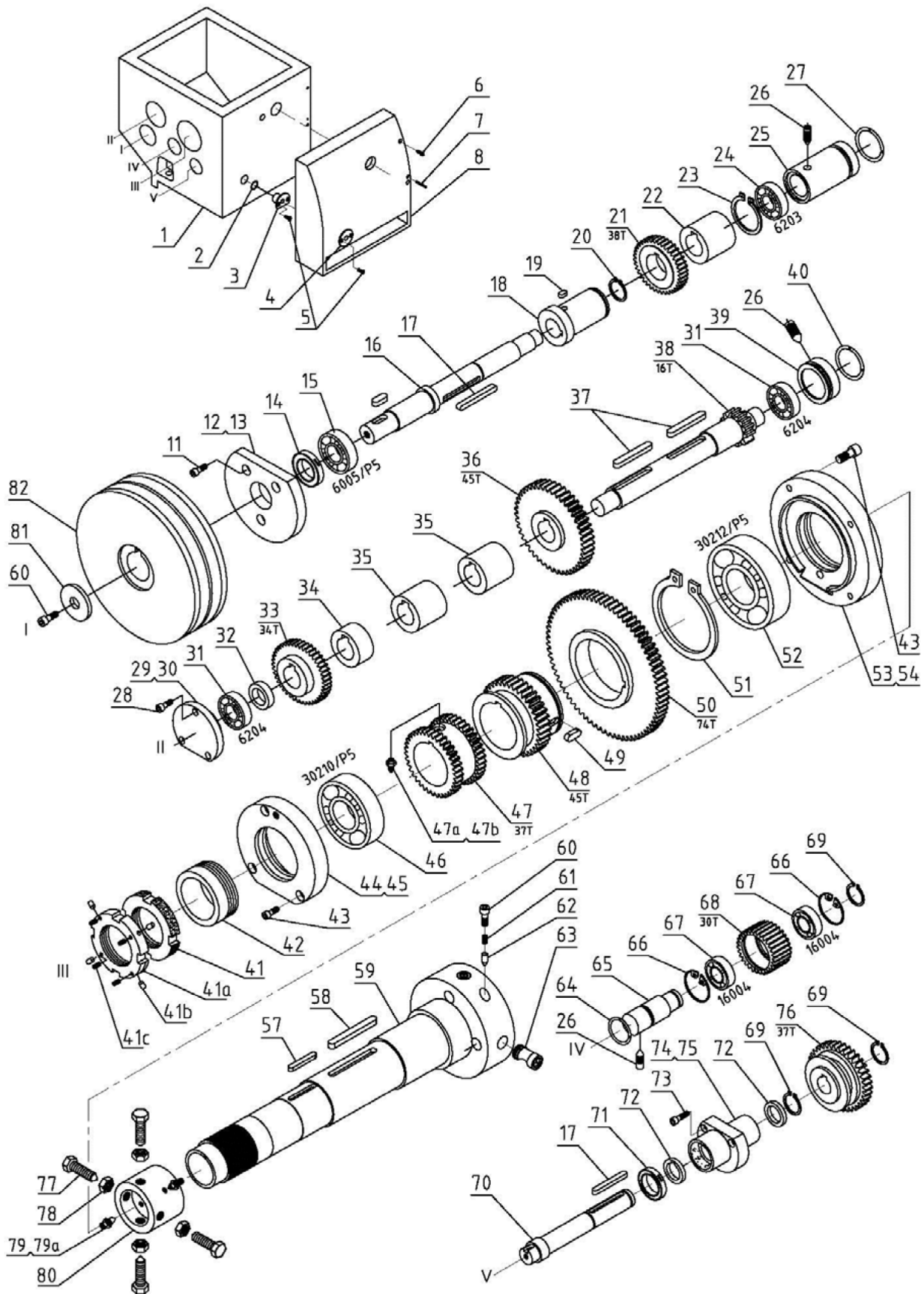

## HEADSTOCK 1 - PARTS LIST

Index No.	Part No.	Description	Size	Qty
1	D330A-21107	HEAD STOCK		1
2	GB/T3452.1-20X2.65	OIL SEAL	20X2.65	1
3	D330A-21246	SLEEVE		1
4	D330A-21235	SLEEVE		1
5	GB/T819-M4X8	SCREW	M4X8	4
6	GB/T70-M6X40	HEX SOCKET CAP SCREW	M6X40	4
7	GB/T879-5X40	PIN	5X40	2
8	D330A-21113-2	CASE FRAME		1
11	GB/T70-M6X20	HEX SOCKET CAP SCREW	M6X20	3
12	D330A-21124	COVER		1
13	D330A-21601	GASKET		1
14	GB/T9877.1-25X40X7	OIL SEAL	25X40X7	1
15	GB/T276-6005	BEARING	6005	1
16	D330DV-21215	SHAFT		1
17	GB/T1096-A6X50	KEY	A6X50	2
18	D330DV-21217	WASHER		1
19	GB/T1096-A6X10	KEY	A6X10	1
20	GB/T894.1-22	CIRCLIP	22	1
21	D330A-21220	GEAR	38T	1
22	D330DV-21221-1	WASHER		1
23	GB/T894.1-35	CIRCLIP		1
24	GB/T276-6203	BEARING	6203	1
25	D330A-21106	FRONT PLUG		1
26	GB/T78-M8X16	SCREW	M8X16	3
27	GB/T3452.1-40X3.1	OIL SEAL	40X3.1	1
28	GB/T70-M4X12	HEX SOCKET CAP SCREW	M4X12	3
29	D330A-21104	COVER		1
30	D330A-21602	GASKET		1
31	GB/T276-6204	BEARING	6204	2
32	D330A-21211	WASHER		1
33	D33D-21223	GEAR	34T	1
34	D330DV-21221	WASHER		1
35	D330D-21221	WASHER		2
36	D330D-21224	GEAR	45T	1
37	GB/T1096-A8X55	KEY	A8X55	2
38	D330A-21212	GEAR SHAFT	16T	1
39	D330A-21225	FRONT PLUG		1
40	GB/T3452.1-47X3.1	OIL SEAL	47X3.1	1
41	D330A-21208	NUT		1
41a	D330AV-21208	NUT		1
41b	~	MAGNET	Ø5X7	4

**NOTE: SOME INDIVIDUAL PARTS MAY ONLY BE AVAILABLE AS AN ASSEMBLY**

HEADSTOCK 1 - PARTS LIST Cont.

Index No.	Part No.	Description	Size	Qty
41c	GB77-M4X6	SCREW	M4X6	4
42	D330A-21102	COLLAR		1
43	GB/T70-M6X25	HEX SOCKET CAP SCREW	M6X25	7
44	D330A-21103	END COVER		1
45	D330A-21603	GASKET		1
46	GB/T297-30210/P5	BEARING	30210/P5	1
47	D330A-21207A	GEAR	37T	1
47a	GB/T78-M4X10	SCREW	M4X10	1
47b	GB/T6170-M4	NUT	M4	1
48	D330AV-21227	GEAR	45T	1
49	GB/T1096-A8X18	KEY	A8X18	1
50	D330A-21226	GEAR	74T	1
51	GB/T894.1-72	CIRCLIP	72	1
52	GB/T297-30212/P5	BEARING	30212/P5	1
53	D330A-21108	FRONT COVER		1
54	D330A-21605	GASKET		1
57	GB/T1096-A6X40	KEY	A6X40	1
58	GB/T1096-A8X85	KEY	A8X85	1
59	D330A-21228A	SPINDLE		1
60	GB/T70-M8X16	HEX SOCKET CAP SCREW	M8X16	4
61	GB2089-4.5X16X0.8	SPRING	4.5X16X0.8	3
62	D330A-21230	PIN		3
63	D330A-21231	CAM		3
64	GB/T3452.1-25X2.4	OIL SEAL	25X2.4	1
65	D330A-21238	SHAFT		1
66	GB/T893.1-42	CIRCLIP	42	2
67	GB/T276-16004	BEARING	16004	2
68	D330A-21237	GEAR	30T	1
69	GB/T894.1-20	CIRCLIP	20	3
70	D330A-21239	SHAFT		1
71	GB/T9877.1-24X32X5	OIL SEAL	24X32X5	1
72	D330A-21202	WASHER		2
73	GB/T70-M5X16	HEX SOCKET CAP SCREW	M5X16	3
74	D330A-21101	COVER		1
75	D330A-21604	GASKET		1
76	D330A-21201	GEAR	37T	1
77	D330A-21302	SCREW		4
78	GB/T6172-M10	GEAR	M10	4
79	GB/T78-M6X16	SCREW	M6X16	2
79a	GB/T6170-M6	NUT	M6	2
80	D330A-21301A	WASHER		1
81	GB/T96-8	WASHER	8	1
82	D330A-21105	PULLEY		1

**NOTE: SOME INDIVIDUAL PARTS MAY ONLY BE AVAILABLE AS AN ASSEMBLY**

HEADSTOCK 2 - DIAGRAM

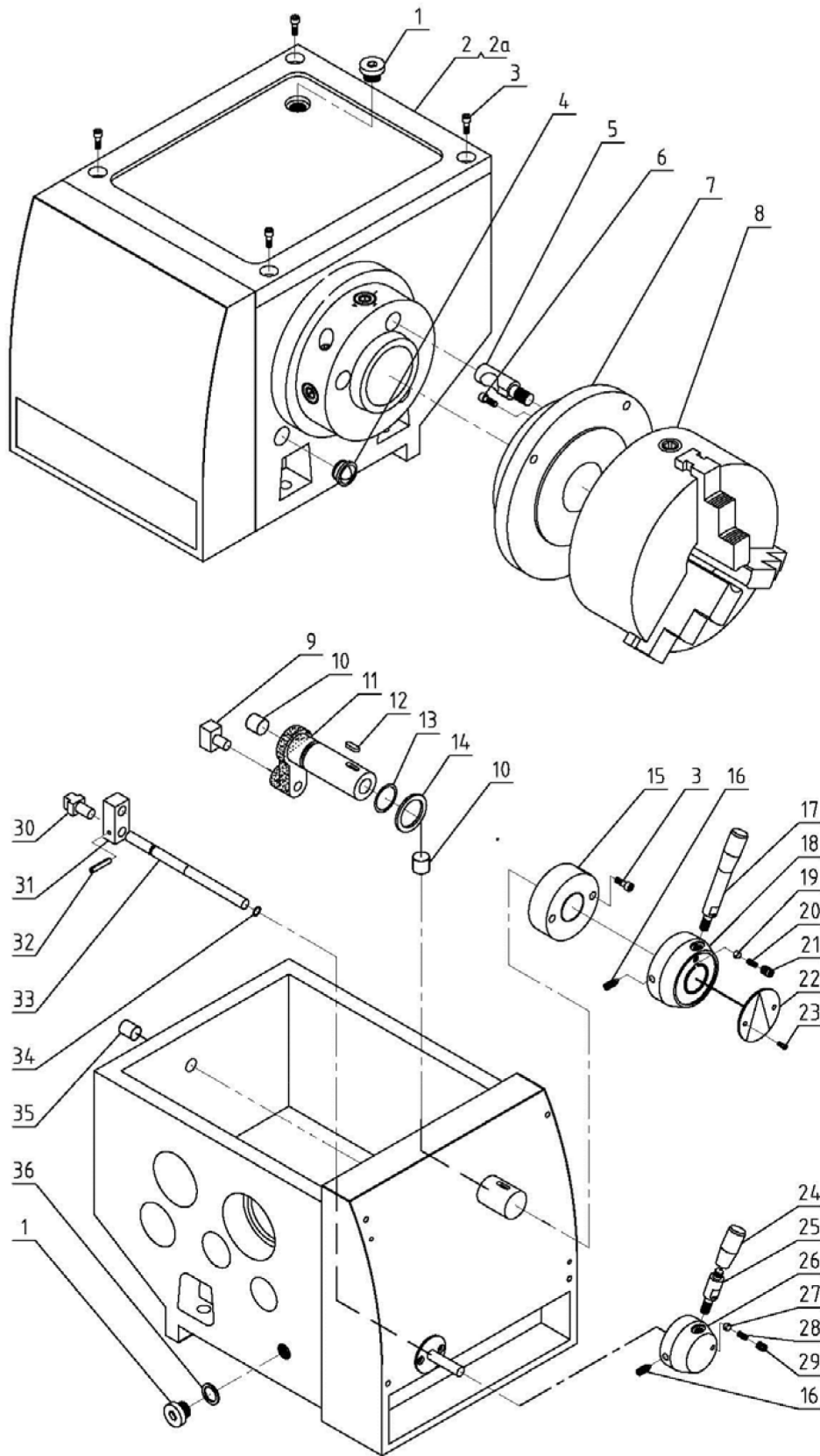

## HEADSTOCK 2 - PARTS LIST

Index No.	Part No.	Description	Size	Qty
1		HEXAGONAL SOCKET HEAD	M16X1.5	2
2	D330A-21112-1	COVER BOARD		1
2a	D330A-21606	GASKET		1
3	GB/T70-M6X25	HEX SOCKET CAP SCREW	M6X25	6
4	JB/T7941.2-M16X1.5	OIL SIGHT	M16X1.5	1
5	D330A-81201	CAM LOCK STUD		3
6	GB/T70-M6X12	HEX SOCKET CAP SCREW	M6X12	3
7		BACK PLATE FOR 3-JAW		1
8		THREE JAW CHUCK		1
9	D330A-21403	SHIFT FORK		1
10	D330DV-21233	FRONT PLUG	Ø16	2
11	D330AV-21121	SHIFT COLLAR		1
12	GB/T1096-A5X14	KEY	A5X14	1
13	GB/T3452.1-30X3.1	OIL SEAL	30X3.1	1
14	D330A-21240	WASHER		1
15	D330AV-21118	HANDLE BASE		1
16	GB/T78-M6X16	SCREW	M6X16	2
17	D330A-21249	HANDLE		1
18	D330DV-21117	HANDLE BASE		1
19	GB308-6	BALL	6	1
20	GB2089-6X26X1	SPRING	6X26X1	1
21	GB/T77-M8X8	SCREW	M8X8	1
22		POSITION SIGN PLATE		1
23	GB/T818-M4X6	SCREW	M4X6	2
24	GB7271.3-M8	COVER	M8	2
25	D330A-21248	HANDLE		1
26	D330A-21120	HANDLE BASE		1
27	GB308-5	BALL		1
28	GB2089-6X26X1	SPRING	5X25X0.8	1
29	GB/T77-M6X8	LOCK SCREW	M6X8	1
30	D330A-21402	SHIFT FORK		1
31	D330A-21111	ROCKER		1
32	GB/T879-4X18	PIN	4X18	1
33	D330A-21236-1	SHAFT		1
34	GB/T3452.1-10X1.9	OIL SEAL	10X1.9	1
35	D330DV-21232	FRONT PLUG	Ø14	2
36		COPPER WASHER	16	1

**NOTE: SOME INDIVIDUAL PARTS MAY ONLY BE AVAILABLE AS AN ASSEMBLY**

GEARBOX 1 - DIAGRAM

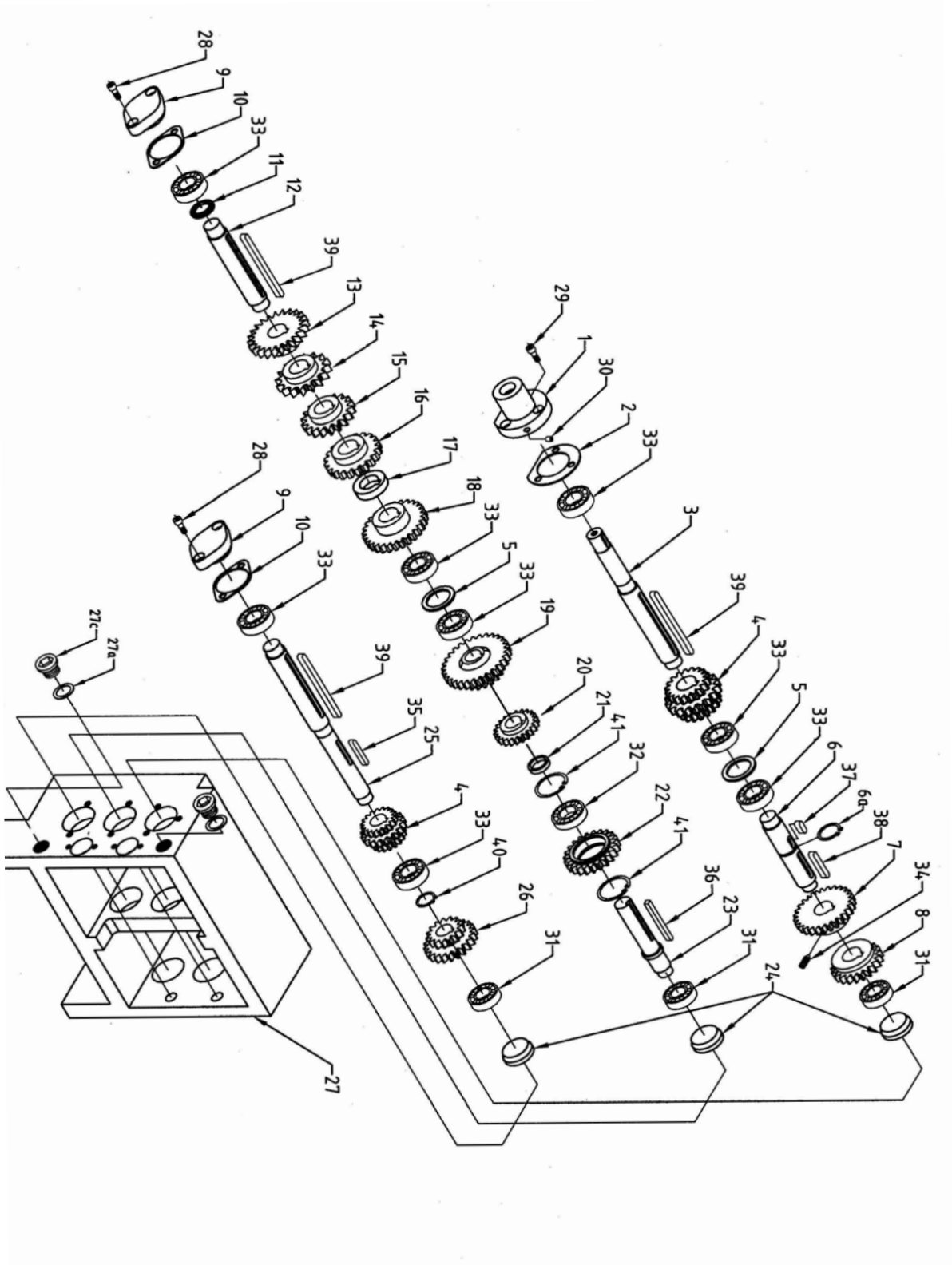

GEARBOX 2 - DIAGRAM

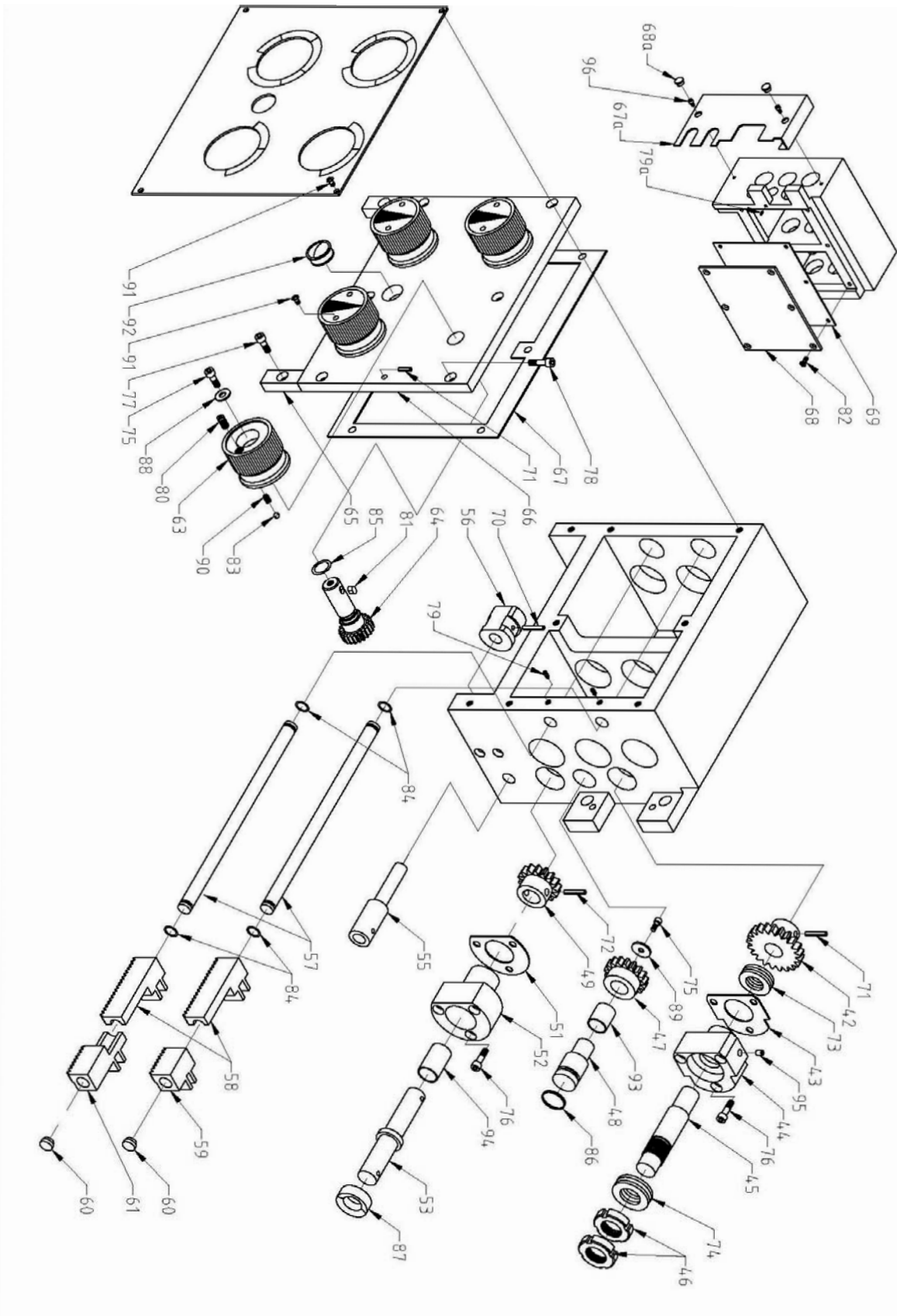

## GEARBOX - PARTS LIST

Index No.	Part No.	Description	Size	Qty
1	D330A-3034	COVER		1
2	D330A-3035	OIL SEAL		1
3	D330A-3041	SHAFT		1
4	D330A-3005	GEAR		2
5	D330A-3066	WASHER		2
6	D330A-3067	SHAFT		1
6a	GB894.1-20	CIRCLIP	20	1
7	D330A-3027	GEAR		1
8	D330A-3025	GEAR		2
9	D330A-3044	COVER		2
10	D330A-3046	OIL SEAL		2
11	D330A-3045	WASHER		1
12	D330A-3033	SHAFT		1
13	D330A-3029	GEAR		1
14	D330A-3031	GEAR		1
15	D330A-3032	GEAR		1
16	D330A-3003	GEAR		1
17	D330A-3030	WASHER		1
18	D330A-3002	GEAR		1
19	D330A-3026	GEAR		1
20	D330A-3007	GEAR		1
21	D330A-3008	WASHER		1
22	D330A-3009	GEAR		1
23	D330A-3019	SHAFT		1
24	CQ6230-3017B	COVER		3
25	D330A-3004	SHAFT		1
26	D330A-3006	GEAR		1
27	CQ6230-3001E	GEAR BOX		1
27a		COPPER WASHER	16	1
27c		SCREW	M16X1.5	2
28	GB/T70-M6X12	HEX SOCKET CAP SCREW	M6X12	4
29	GB/T70-M6X16	HEX SOCKET CAP SCREW	M6X16	3
30	JB/T7940.4-6	OIL PROT	6	1
31	GB/T276-6002	BEARING	6002	3
32	GB/T276-16003	BEARING	16003	1
33	GB/T276-6003	BEARING	6003	8
34	GB/T78-M6X8	SCREW	M6X8	1
35	GB/T1096-A5X35	KEY	A5X35	1
36	GB/T1096-C5X40	KEY	C5X40	1
37	GB/T1096-A6X15	KEY	A6X15	1
38	GB/T1096-A6X35	KEY	A6X35	1
39	GB/T1096-A6X90	KEY	A6X90	3
40	GB/T894.1-17	CIRCLIP	17	1
41	GB/T893.1-35	CIRCLIP	35	2
42	.D330A-3018	GEAR		1
43	CQ6230-3068D	OIL SEAL		1
44	CQ6230-3084D	COVER		1
45	D330 A-3021	SHAFT		1

**NOTE: SOME INDIVIDUAL PARTS MAY ONLY BE AVAILABLE AS AN ASSEMBLY**

GEARBOX - PARTS LIST Cont.

Index No.	Part No.	Description	Size	Qty
46	D330A-GB812	NUT		2
47	D330A-3016	GEAR		1
48	D330A-3015	SHAFT		1
49	D330A-3014	GEAR		1
51	CQ6230-3086D	OIL SEAL		1
52	CQ6230-3022F	COVER		1
53	CQ6230-3013D	SHAFT		1
55	CQ6230-3011D	SHAFT		1
56	D330A-3012	POSITION PIECE		1
57	CQ6230-3089A	SHAFT		2
58	CQ6230-3049C	GEAR RACK		2
59	CQ6230-3062C	GEAR RACK		1
60	CQ6230-3091B	COVER		2
61	CQ6230-3050C	GEAR RACK		1
63	CQ6230-3054F	BOSS		4
64	CQ6230-3088	GEAR		4
65	CQ6230-3061B	WASHER		2
66	CQ6230-3059E	COVER		1
67	CQ6230-3087D	OIL SEAL		1
67a	D330A-3001A	COVER		1
68	D330A-3042	COVER		1
68a		COVER	Ø13	2
69	D330A-3070	OIL SEAL		1
70	GB/T879-4X28	PIN	4X28	1
71	GB/T879-5X26	PIN	5X26	2
72	GB/T879-5X28	PIN	5X28	2
73	GB/T301-51103	BEARING		1
74	GB/T301-51104	BEARING		1
75	GB/T70- M6X12	HEX SOCKET CAP SCREW	M6X12	5
76	GB/T70- M6X25	HEX SOCKET CAP SCREW	M6X25	6
77	GB/T70- M8X16	HEX SOCKET CAP SCREW	M8X16	2
78	GB/T70- M8X20	HEX SOCKET CAP SCREW	M8X20	6
79	GB/T78- M4X8	SCREW	M4X8	2
79a	GB/T78- M5X8	SCREW	M5X8	1
80	GB/T77- M8X6...	SCREW	M8X6	4
81	GB/T1096-A5X8	KEY	A5X8	4
82	GB/T819-M6X10	SCREW	M6X10	6
83	GB308-89-6	BALL	6	4
84	GB/T3452.1-12X1.8	OIL SEAL	12X1.8	4
85	GB/T3452.1-16X2.4	OIL SEAL	16X2.4	4
86	GB/T3452.1-22X2.4	OIL SEAL	22X2.4	1
87	GB/T9877.1-18X30X10	OIL SEAL	18X30X10	1
88	GB/T97.1-6	WASHER	6	4
89	GB/T96-6	WASHER	6	1
90	GB2089-6X18X0.8	SPRING	6X18X0.8	4
91	GB/T818-M4X6	SCREW	M4X6	12
92		OIL SEAL	M22X1.5	1
93		COPPER WASHER	16X18X20	1
94		COPPER WASHER	17X19X30	1
95	JB/T7940.4-6	OIL PORT	6	1
96	GB/T70-M5X8	HEX SOCKET CAP SCREW	M5X8	2

**NOTE: SOME INDIVIDUAL PARTS MAY ONLY BE AVAILABLE AS AN ASSEMBLY**

APRON - DIAGRAM

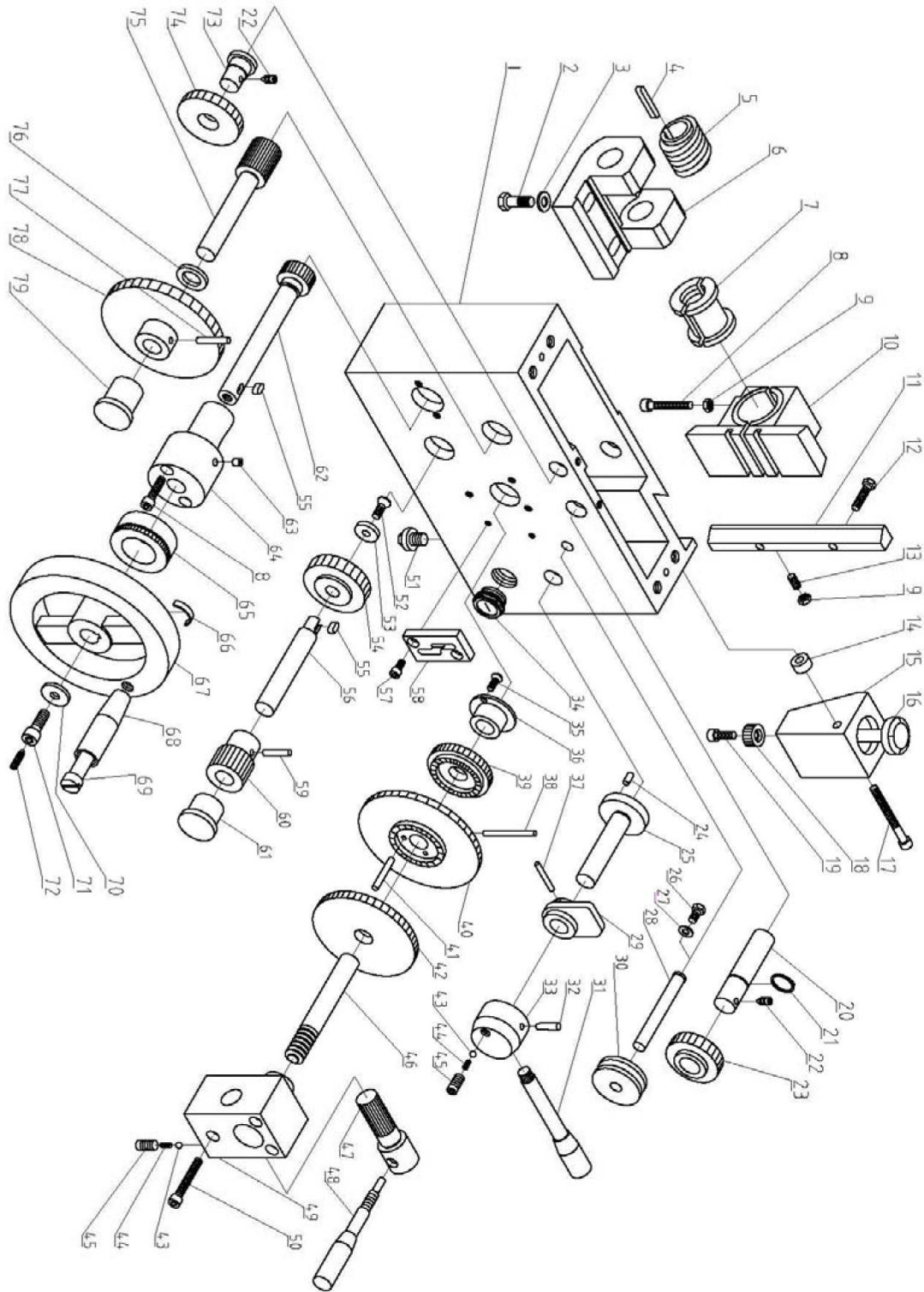

## APRON - PARTS LIST

Index No.	Part No.	Description	Size	Qty
1	CQ6230-4001	APRON CASTING		1
2	GB/T5782-M8X30	CAP SCREW	M8X30	2
3	GB/T97.1-8	WASHER	8	2
4	GB/T1096-5X36	KEY	5X36	1
5	CQ6230-4008	WORM		1
6	CQ6230-4009	BRACKET		1
7	CQ6230-4003	HALF NUT		1
8	GB/T70-M6X40	CAP SCREW	M6X40	3
9	GB/T6175-M6	NUT	M6	3
10	CQ6230-4002	BRACKET		1
11	CQ6230-4022	GIB		1
12	GB/T5782-M6X25	CAP SCREW	M6X25	2
13	GB/T77-M6X15	SCREW	M6X15	2
14	CQ6230-4007	WASHER		1
15	CQ6230-4005	BRACKET		1
16	CQ6230-4006	SHAFT		1
17	GB/T70-M6X60	CAP SCREW	M6X60	1
18	CQ6230-4004	GEAR		1
19	GB/T70-M6X15	CAP SCREW	M6X15	1
20	CQ6230-4046	SHAFT		1
21	GB/T894.1-18	CIRCLIP	18	1
22	GB/T78-M6X6	SCREW	M6X6	2
23	CQ6230-4035	GEAR		1
24	GB/T119-5X10	PIN	5X10	2
25	CQ6230-4023	SHAFT		1
26	GB/T5782-M6X10	CAP SCREW	M6X10	1
27	GB/T97.1-6	WASHER	6	1
28	CQ6230-4024	SHAFT		1
29	CQ6230-4021	LOCATING BLOCK		1
30	CQ6230-4025	FORK		1
31	CQ6230-4044	LEVER		1
32	GB/T117-5X40	TAPER PIN	5X40	1
33	CQ6230-4045	LEVER HAND		1
34	JB/T7941.2-M22X1.5	OIL SEAL	M22X1.5	1
35	GB/T65-M5X12	SCREW	M5X12	2
36	CQ6230-4016	WASHER		1
37	GB/T879-4X30	PIN	4X30	1
38	GB/T879-4X50	PIN	4X50	1
39	CQ6230-4014	GEAR		1
40	CQ6230-4013	GEAR		1

**NOTE: SOME INDIVIDUAL PARTS MAY ONLY BE AVAILABLE AS AN ASSEMBLY**

APRON - PARTS LIST Cont.

Index No.	Part No.	Description	Size	Qty
41	GB/T119-5X33	PIN	5X33	3
42	CQ6230-4013	GEAR		1
43	GB308---6	STEEL BALL	6	2
44	CQ6123-14-01	SPRING		2
45	GB/T77-M8X8	SCREW	M8X8	2
46	CQ6230-4015	SHAFT		1
47	CQ6230-4042	GEAR		1
48	CQ6230-4041	LEVER		1
49	CQ6230-4039	BRACKET		1
50	GB/T70-M6X45	CAP SCREW	M6X45	3
51		BOLT	M10X1	1
52	GB/T819-M6X12	SCREW	M6X12	1
53	CQ6230-4048	WASHER		1
54	CQ6230-4017	GEAR		1
55	GB/T1096-5X10	KEY	5X10	2
56	CQ6230-4018	SHAFT		1
57	GB/T70-M5X10	CAP SCREW	M5X10	2
58	CQ6230-4043	LOCATING BLOCK SHAFT		1
59	GB/T879-5X25	PIN	5X25	1
60	CQ6230-4019	GEAR		1
61	CQ6230-4020	WASHER		1
62	CQ6230-4030	SHAFT		1
63	GB/T7940.4-6	OIL PORT	6	1
64	CQ6230-4031	BRACKET		1
65	CQ6230-4036	GRADUATED DIAL		1
66	CQ6230-4037	CURSOR		1
67	CQ6230-4034	HAND WHEEL		1
68	CQ6230-4032	HANDLE		1
69	CQ6230-4033	HANDLE SCREW		1
70	CQ6230-4038A	WASHER		1
71	CQ6230-4047	SCREW		1
72	GB/T79-5X30	SCREW	5X30	1
73	CQ6230-4011	SHAFT		1
74	CQ6230-4010	GEAR		1
75	CQ6230-4028	SHAFT		1
76	CQ6230-4027	WASHER		1
77	GB/T879-5X30	PIN	5X30	1
78	CQ6230-4029	GEAR		1
79	CQ6230-4026	WASHER		1

**NOTE: SOME INDIVIDUAL PARTS MAY ONLY BE AVAILABLE AS AN ASSEMBLY**

COMPOUND REST - DIAGRAM

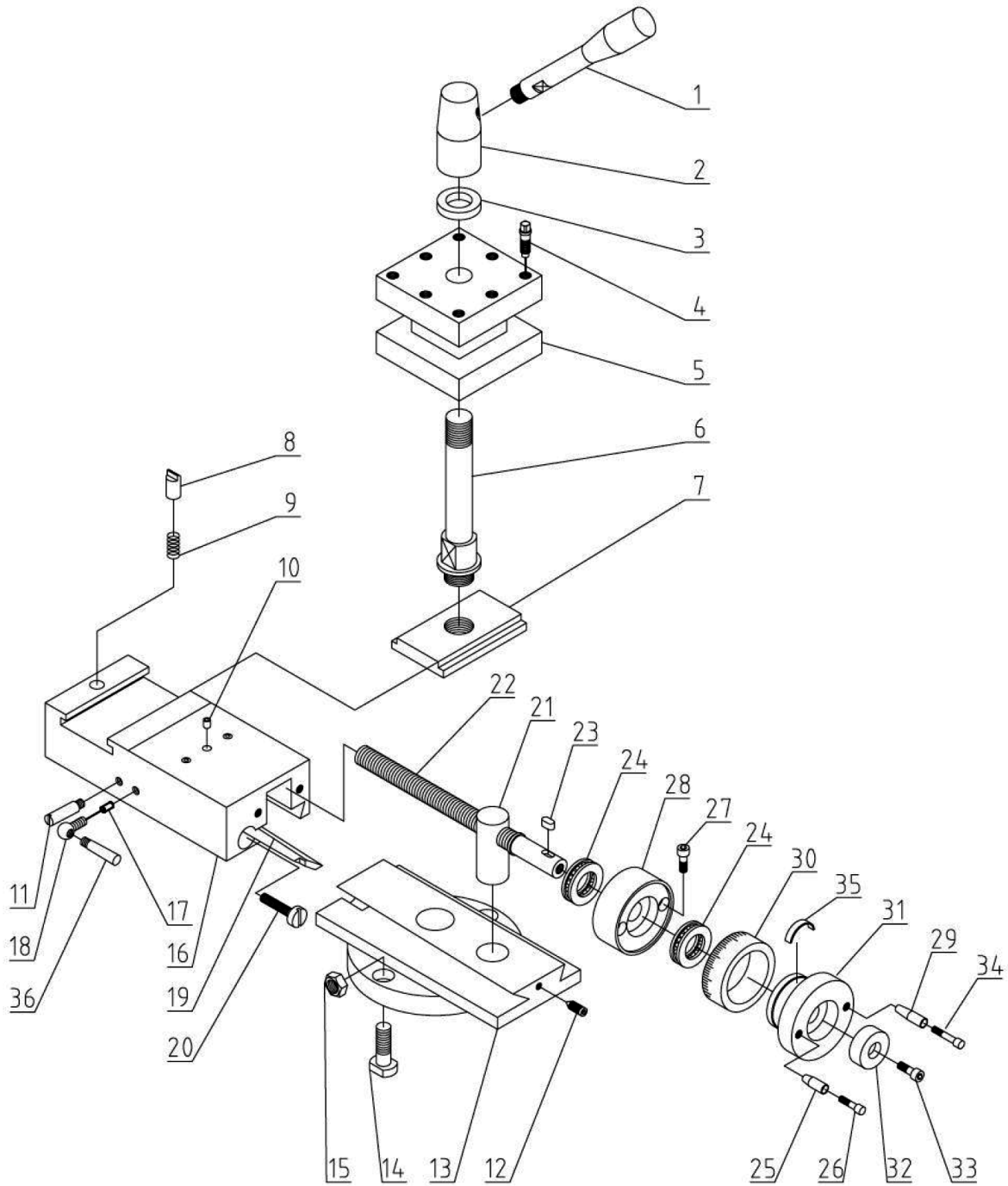

COMPOUND REST - PARTS LISTS

Index No.	Part No.	Description	Size	Qty
1	CQ6230-5010	HANDLE		1
2	CQ6230-5009	BOSS		1
3	CQ6230-5008	COLLAR		1
4	GB/T83-M10x45	SCREW	M10x45	8
5	CQ6230-5005	TOOL POST		1
6	CQ6230-5006	SHAFT		1
7	CQ6230-5003	NUT		1
8	CQ6230-5004	PIN		1
9	GB2089-1.2x6x8	SPRING	1.2x6x8	1
10	JB/T7940.4-6	OIL CUP	6	3
11	D330A-S2003	SHAFT		1
12	GB/T78-M6x16	SCREW	M6x16	1
13	CQ6230-5001	COMPOUND		1
14	D330A-51203	"T" SCREW		2
15	GB/T6175-M10	NUT	M10	2
16	CQ6230-5002	COMPOUND		1
17	CQ6230-5024	PIN		1
18	D330A-S2001	SCREW		1
19	CQ6230-5023	GIB		1
20	CQ6230-5021	SCREW		2
21	CQ6230-5012	NUT		1
22	CQ6230-5011	GUIDE SCREW		1
23	GB/T1096-A4x8	KEY	A4x8	1
24	GB/T301-51101	BEARING		2
25		COLLAR		1
26		BOLT		1
27	GB/T70-M6x25	HEX SOCKET CAP SCREW	M6x25	2
28	CQ6230-5013	BRACKET		1
29		COLLAR		1
30	CQ6230-5014	INDEX RING		1
31		HAND WHEEL		1
32		WASHER		1
33	GB/T70-M6x12	HEX SOCKET CAP SCREW	M6x12	1
34		BOLT		1
35	CQ6230-4037	LEAF SPRING		1
36	D330A-S2002	BOLT		1

**NOTE: SOME INDIVIDUAL PARTS MAY ONLY BE AVAILABLE AS AN ASSEMBLY**

SADDLE - DIAGRAM

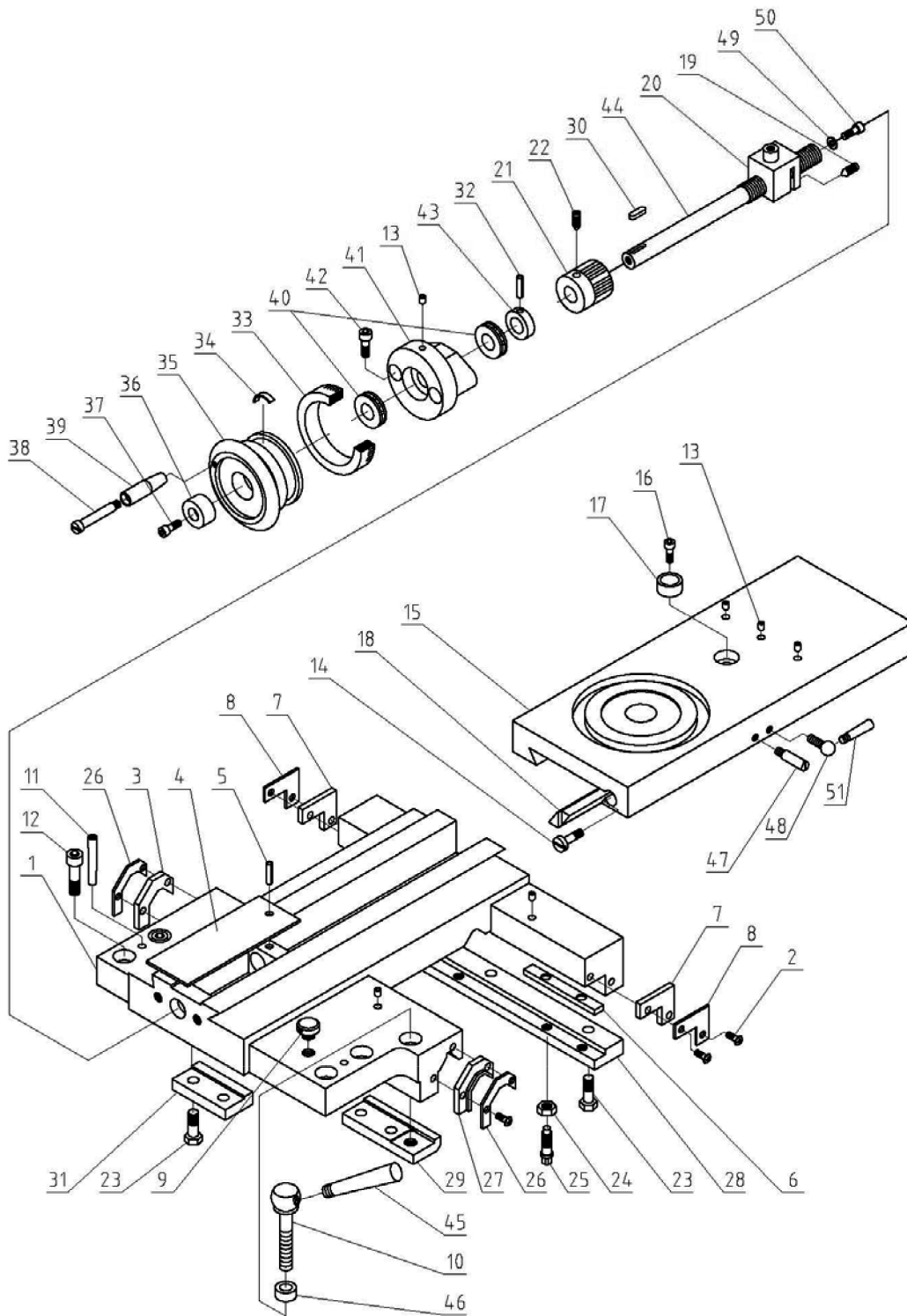

## SADDLE - PARTS LIST

Index No.	Part No.	Description	Size	Qty
1	D330A-51101	SADDLE		1
2	GB818-M5X12	SCREW	M5X12	8
3	D330A-51301	WIPER		1
4	D330A-51211	COVER		1
5	GB/T879-3X10	PIN	3X10	1
6	D330A-51216	PRESS PLATE		2
7	D330A-51303	PRESS PLATE		2
8	D330A-51204	WIPER		2
9	D330A-51215	SCREW		1
10	D330A-S1001	SCREW		1
11	GB/T118-6X45	TAPER PIN	6X45	2
12	GB/T70-M10x30	HEX SOCKET CAP SCREW	M10x30	4
13	JB/T7940.4-6	OIL CUP	6	6
14	D330A-51214	SCREW		2
15	D330A-51102	TOOL POST		1
16	GB/T70-M6x12	HEX SOCKET CAP SCREW	M6x12	1
17	D330A-51201	BUSHING		1
18	D330A-51212	GIB		1
19	GB/T78-M4x12	SCREW	M4x12	2
20	D330A-51401	NUT		1
21	D330A-51202	GEAR		1
22	B/T78-M6x8	SCREW	M6x8	1
23	GB/T5782-M8x25	SCREW	M8x25	7
24	GB/T6175-M8	NUT	M8	4
25	GB/T83-M8x25	SCREW	M8x25	4
26	D330A-51205	PRESS PLATE		2
27	D330A-51302	WIPPER		1
28	D330A-51104	PRESS PLATE		1
29	D330A-51105	PRESS PLATE		1
30	GB/T1096-5x20	KEY	5x20	1
31	D330A-51103	PRESS PLATE		1
32	GB/T879-4X25	PIN	4X25	1
33	D330A-51208	INDEX RING		1
34	CQ6230-4037	LEAF SPRING		1
35	D330A-51207	HAND WHEEL		1
36	D330A-51207-1	WASHER		1
37	GB/T70-M6x16	HEX SOCKET CAP SCREW	M6x16	1
38	JD10-06027A	HANDLE SCREW		1
39	JD10-06027	HANDLE		1
40	GB/T301-51102	BEARING	51102	2
41	D330A-51106	BRACKET		1
42	GB/T70-M8x30	HEX SOCKET CAP SCREW	M8x30	2
43	D330A-51210	WASHER		1
44	D330A-51206	GUIDE SCREW		1
45	D330A-S1002	HANDLE		1
46	D330A-S1003	LOCK HANDLE		1
47	D330A-S2003	SCREW		1
48	D330A-S2001	SCREW		1
49	GB/T97.1-5	WASHER	5	1
50	GB/T70-M5x12	HEX SOCKET CAP SCREW	M5x12	1
51	D330A-S2002	HANDLE		1

**NOTE: SOME INDIVIDUAL PARTS MAY ONLY BE AVAILABLE AS AN ASSEMBLY**

TAILSTOCK - DIAGRAM

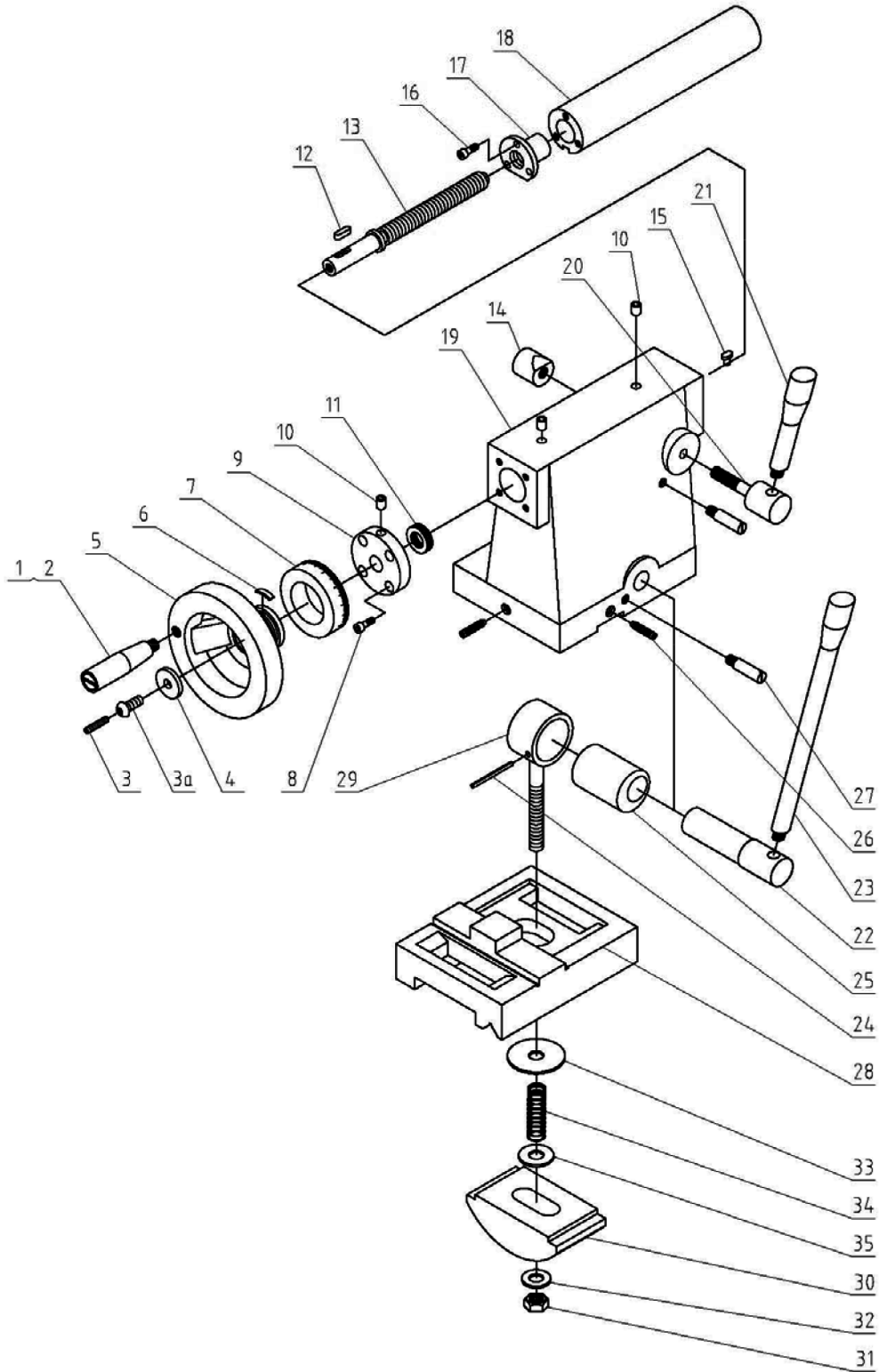

TAILSTOCK - PARTS LIST

Index No.	Part No.	Description	Size	Qty
1	CQ6230-4033	HANDLE		1
2	CQ6230-4032	LEVER		1
3	GB/T77-M5X25	SCREW	M5X25	1
3a	D330A-6044	ADJUSTING SCREW		1
4	D330A-6045	WASHER		1
5	D330A-6005	HAND WHEEL		1
6	CQ6230-4037	LEAF SPRING		1
7	D330A-6010	INDEX RING		1
8	GB/T70-M6X16	HEX SOCKET CAP SCREW	M6X16	4
9	D330A-6011	BRACKET		1
10	JB/T7940.4-8	OIL CUP	8	3
11	GB/T301-51102	BEARING		1
12	GB/T1096-A4X15	KEY	A4X15	1
13	D330A-6006	GUIDE SCREW		1
14	D330A-6023	LOCK NUT		1
15	D330A-6015	KEY		1
16	GB/T70-M4x12	HEX SOCKET CAP SCREW	M4x12	3
17	D330A-6012	NUT		1
18	D330A-6013	QUILL		1
19	D330A-6001	TAIL STOCK		1
20	D330A-6022	LOCK SCREW		1
21	D330A-6021	HANDLE		1
22	D330A-6017	SHAFT		1
23	D330A-6004	HANDLE		1
24	GB/T119-5x30	PIN	5x30	1
25	D330A-6018	COLLAR		1
26	GB/T79-M10x50	SCREW	M10x50	3
27	D330A-6003	SCREW		2
28	D330A-6002	BASE		1
29	D330A-6019	SHAFT		1
30	D330A-6020	BASE SHOE BLACK		1
31	GB/T6175-M12	NUT	M12	1
32	GB/T97.1-12	WASHER		1
33	D330A-6042	WASHER		1
34	D330A-6041	SPRING		1
35	D330A-6043	WASHER		1

**NOTE: SOME INDIVIDUAL PARTS MAY ONLY BE AVAILABLE AS AN ASSEMBLY**

CHANGE GEARS - DIAGRAM

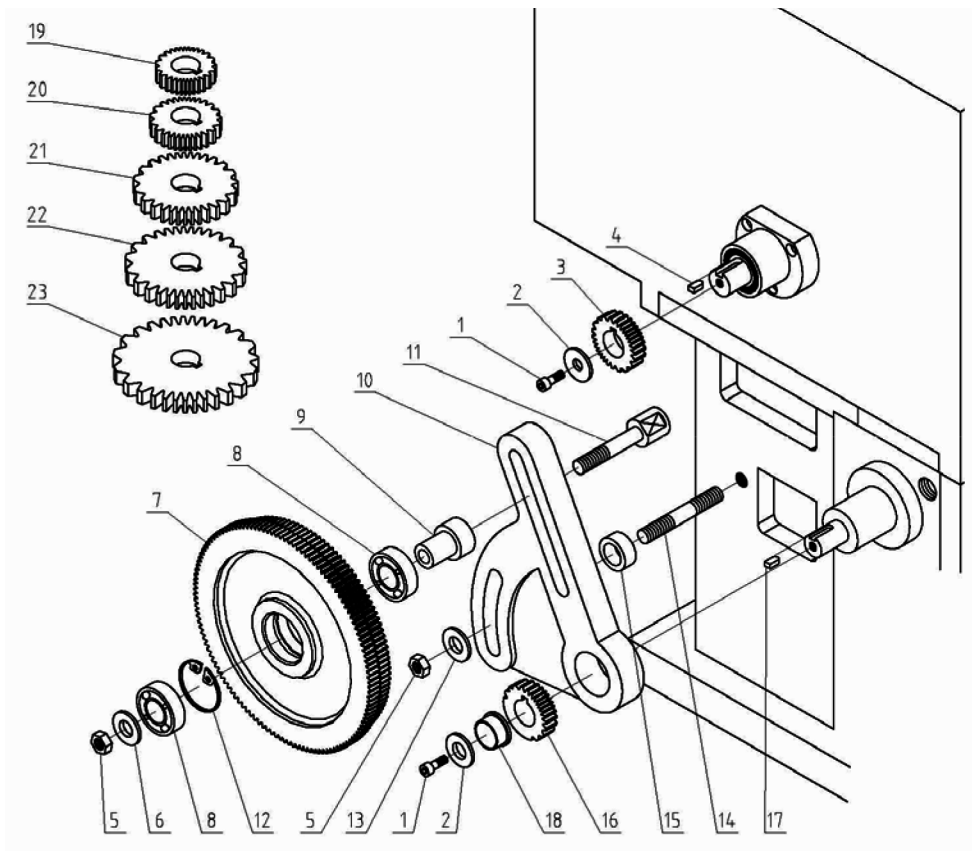

CHANGE GEARS - PARTS LIST

Index No.	Part No.	Description	Size	Qty
1	GB/T70-M6X12	HEX SOCKET CAP SCREW	M6X12	2
2	GB/T96-6	WASHER	6	2
3	D330A-91202	GEAR	24T	1
4	GB/T1096-A5X8	KEY	A5X8	1
5	GB/T6175-M10	NUT	M10	2
6	GB/T97.1-10	WASHER	10	1
7	D330A-91208	GEAR	120/127T	1
8	GB/T276-6003	BEARING		2
9	D330A-91209	COLLAR		1
10	D330A-91101	QUADRANT		1
11	D330A-91210	SCREW		1
12	GB/T893.1-35	CIRCLIP	35	1
13	GB/T97.1-10	WASHER	10	1
14	GB/T901-M10X60	SCREW	M10X60	1
15	D330A-91212	WASHER		1
16	D330A-91206	GEAR	48T	1
17	GB/T1096-A5X8	KEY	A5X8	1
18	D330A-91213-1	WASHER		1
19	D330A-91201	CHANGE GEAR	22T	1
20	D330A-91203	CHANGE GEAR	26T	1
21	D330A-91204	CHANGE GEAR	38T	1
22	D330A-91205	CHANGE GEAR	44T	1
23	D330A-91207	CHANGE GEAR	52T	1

CONTROL SWITCH ASSEMBLY - DIAGRAM

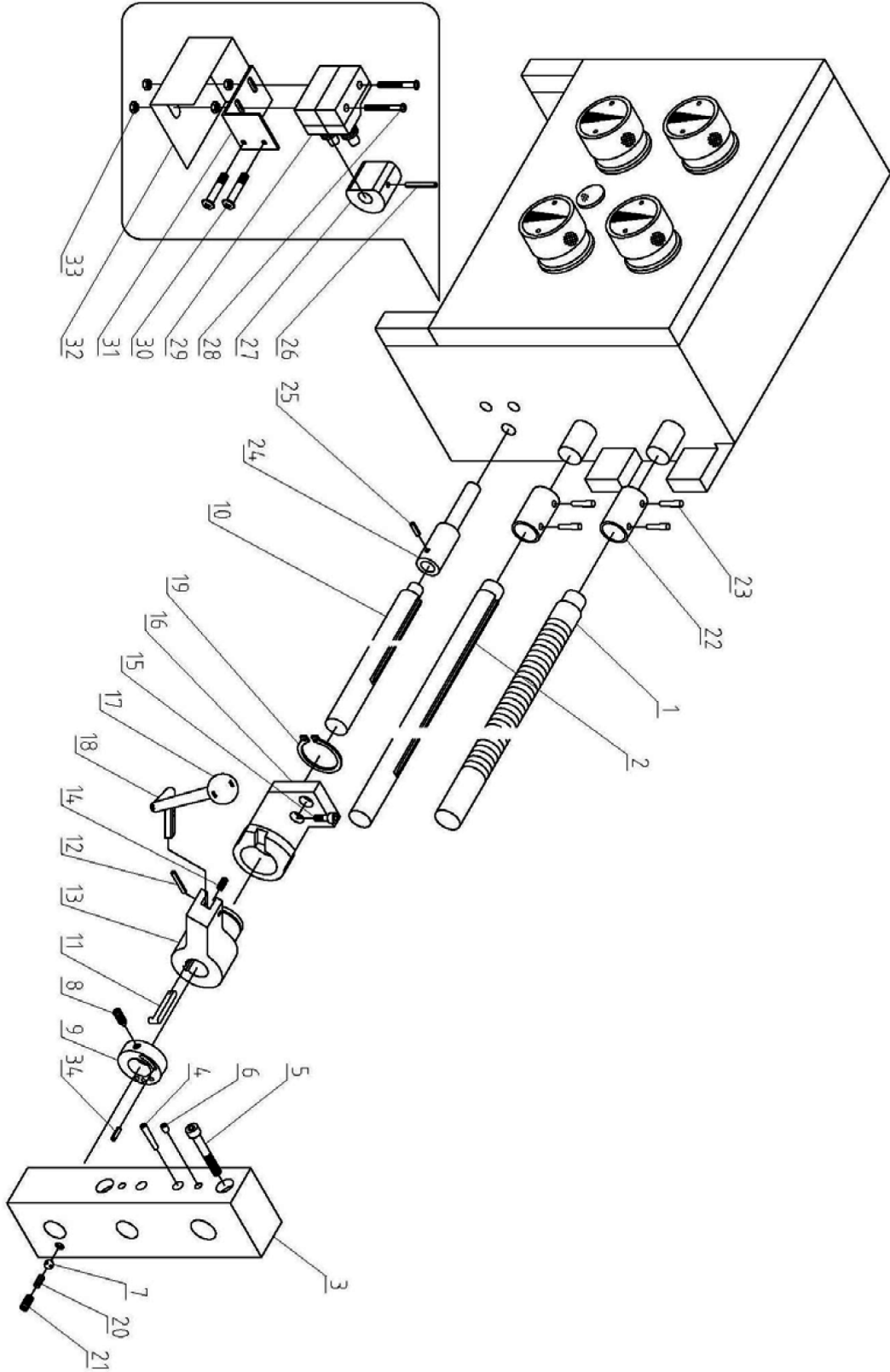

## CONTROL SWITCH ASSEMBLY - PARTS LIST

Index No.	Part No.	Description	Size	Qty
1	D330A-11201	GUIDE SCREW		1
2	D330A-11202	ROD		1
3	D330A-11102	BRACKET		1
4	GB/T118-6X45	TAPER PIN	6X45	2
5	GB/T70-M8X60	HEX SOCKET CAP SCREW	M8X60	2
6	JB/T7940.4-6	OIL CUP	6	2
7	GB308---6	BALL	6	1
8	GB/T78-M6x10	SCREW	M6x10	1
9	D330A-11209-1	BUSHING		1
10	D330A-11203	FEED ROD		1
11	D330A-11104-1	KEY		1
12	GB/T879-4X25	PIN	4X25	1
13	D330A-11104	BRACKET		1
14	GB2089-10X1X12	SPRING	10X1X12	1
15	GB/T70-M6X12	HEX SOCKET CAP SCREW	M6X12	2
16	D330A-11105	BRACKET		1
17	JB/T7271.1-M10X32	HANDLE BALL	M10X32	1
18	D330A-11206	HANDLE		1
19	GB/T894.1-32	CIRCLIP	32	1
20	GB2089-1x5x30	SPRING	1x5x30	1
21	GB/T77-M8X8	SCREW	M8X8	1
22	D330A-11207	WASHER		2
23	GB/T879-4X24	PIN	4X24	4
24	CQ6230-3011D	SHAFT		1
25	GB/T879-4X20	PIN	4X20	1
26	GB/T879-4X30	PIN	4X30	1
27	D330A-3012	POSITION PIECE		1
28	GB818-M4X50	SCREW	M4X50	2
29		SWITCH	LXW5-11M	2
30	GB818-M4X20	SCREW	M4X20	2
31	D330A-71207	BRACKET		1
32	D330A-71207-1	COVER		1
33	GB/T6175-M4	NUT	M4	4
34	GB/T879-4X12	PIN	4X12	1

**NOTE: SOME INDIVIDUAL PARTS MAY ONLY BE AVAILABLE AS AN ASSEMBLY**

BED AND DRIVE ASSEMBLY - DIAGRAM

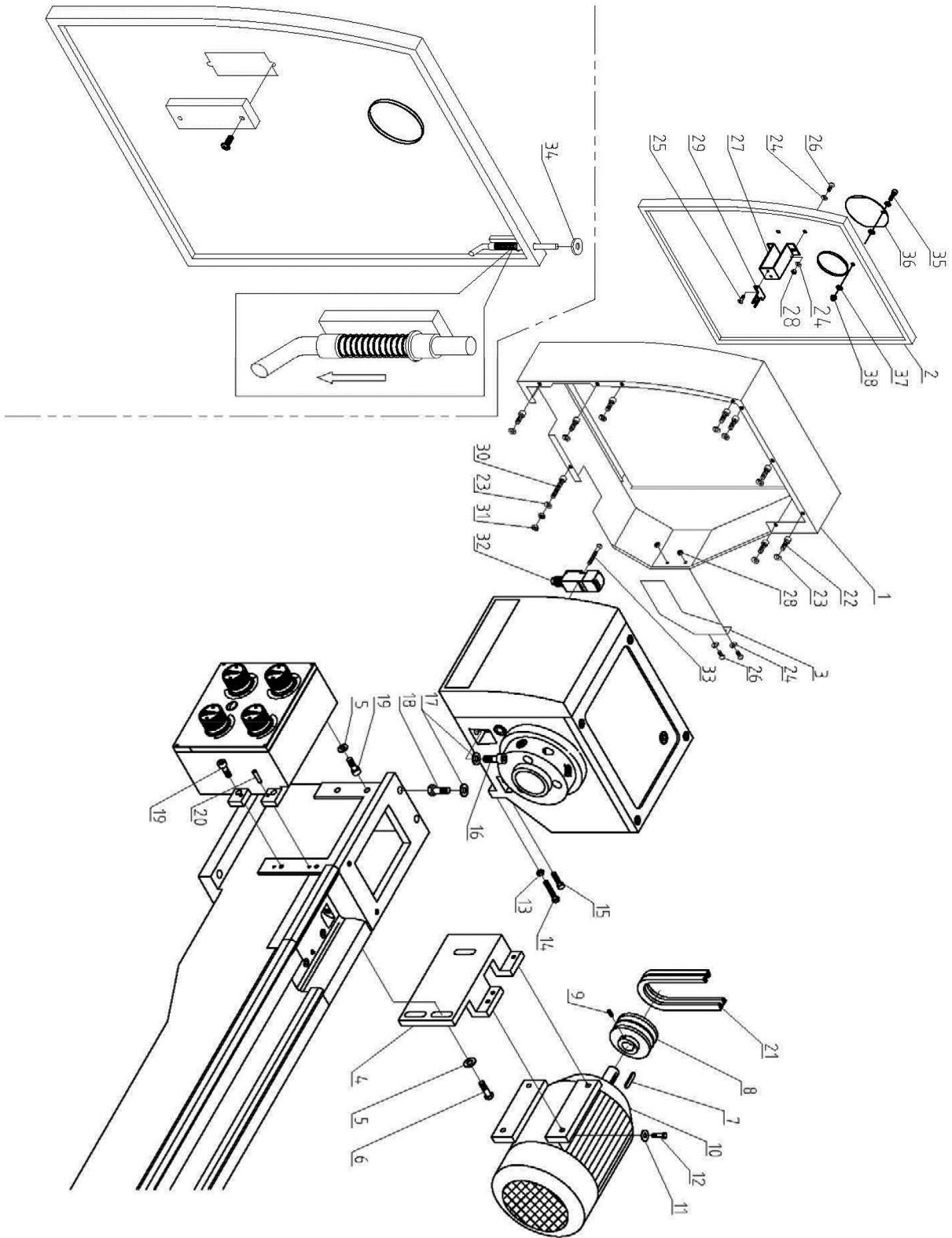

## BED AND DRIVE ASSEMBLY - PART LIST

Index No.	Part No.	Description	Size	Qty
1	D330A-13401A-1	COVER		1
2	D330A-13402A-1	COVER		1
3	D330A-14220	COVER		1
4	D330A-11107	TRESTLE		1
5	GB/T97.1-10	WASHER	10	5
6	GB/T5782-M10X30	SCREW	M10X30	3
7	GB/T1096-8X35	KEY	8X35	1
8	D330A-11106	PULLEY		1
9	GB/T78-M6X8	SCREW	M6X8	1
10		MOTOR		1
11	GB/T97.1-8	WASHER	8	4
12	GB/T5782-M8X25	SCREW	M8X25	4
13	GB/T6175-M8	NUT	M8	2
14	GB/T5782-M8X45	SCREW	M8X45	2
15	GB/T70-M8X30	HEX SOCKET CAP SCREW	M8X30	2
16	GB/T70-M12X35	HEX SOCKET CAP SCREW	M12X35	2
17	GB/T97.1-12	WASHER	12	4
18	GB/T5782-M12X30	SCREW	M12X30	2
19	GB/T70-M10X30	HEX SOCKET CAP SCREW	M10X30	4
20	GB/T117-6X30	TAPER PIN	6X30	2
21		V-BELT	AV13-895	2
22	GB/T70-M5X8	HEX SOCKET CAP SCREW	M5X8	8
23	GB/T97.1-5	WASHER	5	9
24	GB/T97.1-4	WASHER	4	6
25	GB818-M4X6	SCREW	M4X6	2
26	GB818-M4X10	SCREW	M4X10	4
27	D330A-71209	BRACKET		1
28	GB/T6175-M4	NUT	M4	4
29		SWITCH-1	QKS8	1
30	GB/T70-M5X30	HEX SOCKET CAP SCREW	M5X30	1
31	GB/T6175-M5	NUT	M5	2
32		SWITCH-2	QKS8	1
33	GB818-M4X30	SCREW	M4X30	2
34		WASHER		2
35	GB/T70-M6X12	HEX SOCKET CAP SCREW	M6X12	1
36	D330D-14208B-1	COVER		1
37	GB/T97.1-6	WASHER	6	3
38		NUT	M6	1

**NOTE: SOME INDIVIDUAL PARTS MAY ONLY BE AVAILABLE AS AN ASSEMBLY**

STAND / COOLANT PUMP / LAMP - DIAGRAM 1

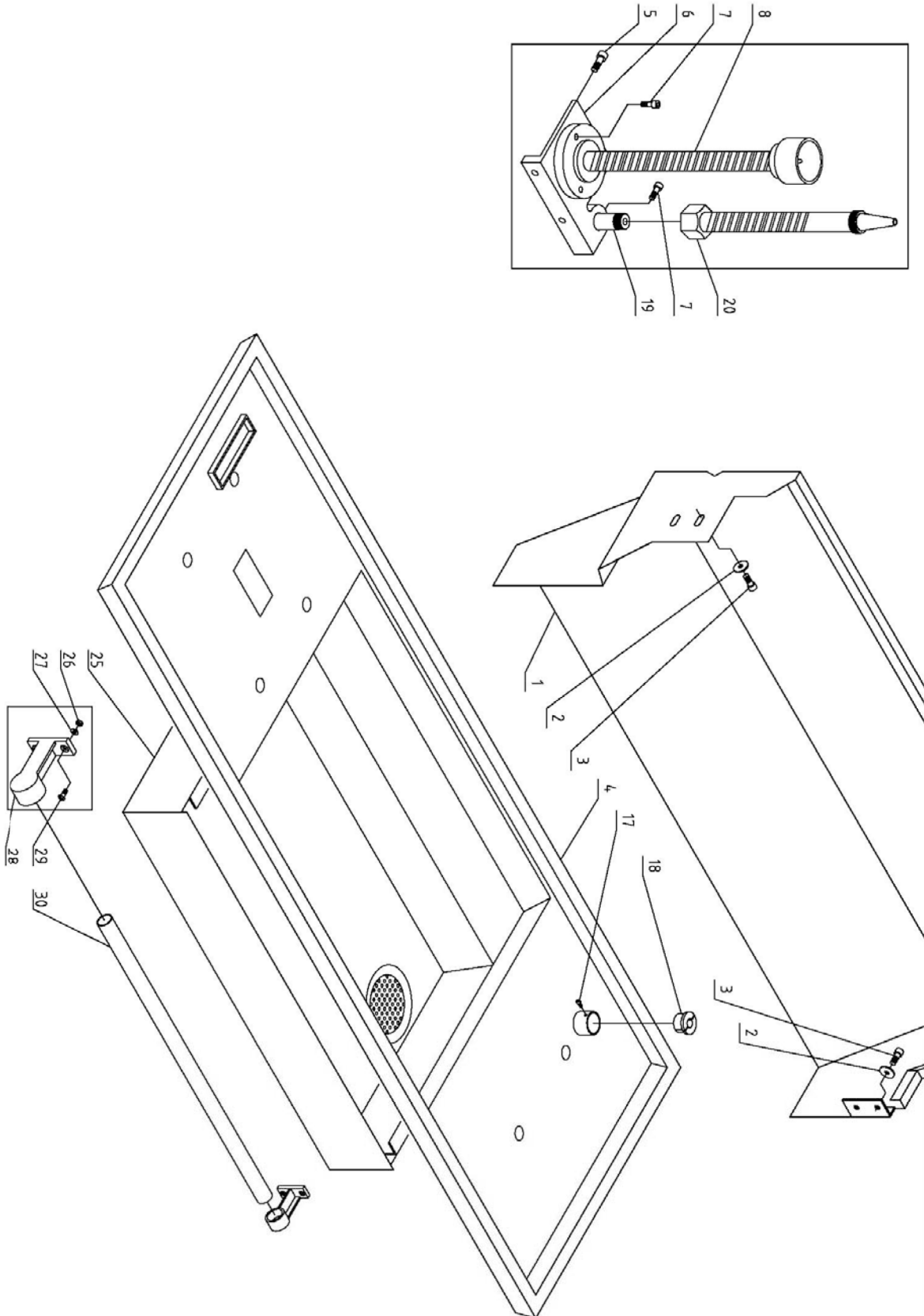

STAND / COOLANT PUMP / FOOTBRAKE - DIAGRAM 2

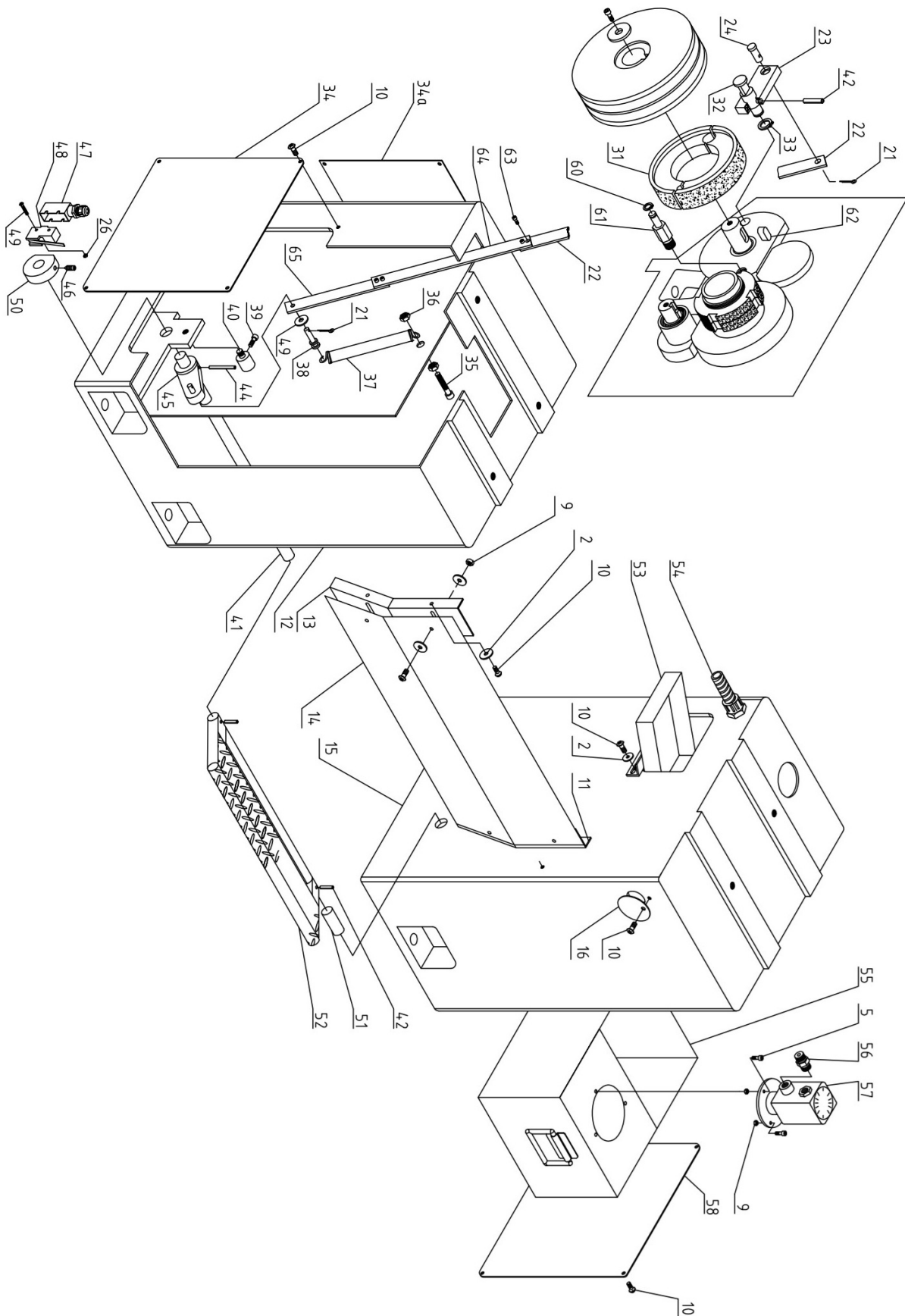

STAND / COOLANT PUMP / FOOTBRAKE - PARTS LIST

Index No.	Part No.	Description	Size	Qty
2	GB/T97.1	FLAT WASHER	6	14
5	GB/T70	HEX SOCKET CAP SCREW	M6X20	6
9	GB/T6170	HEX NUT	M6	8
10	GB/T818	SCREW	M6X10	26
11	D330B-14206-1	RIGHT BRACKET		1
12	D330A-14201D	LEFT STAND		1
13	D330B-14206	LEFT BRACKET		1
14	D330A-14207-1	BACK PLATE		1
15	D330A-14202D	RIGHT STAND		1
16	D330D-14208B	COVER		4
21	GB/T91	PIN	3X16	2
22	D330A-14214-1	BRAKE LINKAGE UPPER		1
23	D330B-14218	ROCKER		1
24	D330A-11239	ROCKER SHAFT		1
26	GB/T6170	HEX NUT	M4	2
31		PULLEY BRAKE ASSEMBLY	25X125	1
32	D330A-11230	ROCKER SHAFT		1
33	GB894.1	EXT RETAINING RING	12	1
34	D330A-14209A	LEFT STAND COVER-SIDE		1
34a	D330A-14210A	LEFT STAND COVER-REAR		1
35	GB/T70	HEX SOCKET CAP SCREW	M10X30	1
36	GB/T6170	HEX NUT	M10	2
37	D330A-11237	EXTENSION SPRING		1
38	D330A-11236	SPRING RETENTION PIN		1
39	GB/T70	HEX SOCKET CAP SCREW	M6X40	1
40	D330A-11242	BRAKE HEAD STOP		1
41	D330B-14215	BRAKE PEDAL SHAFT-LEFT		1
42	GB/T879	ROLL PIN	5X28	3
44	GB/T879	ROLL PIN	5X40	1
45	D330A-11235	BRAKE ROCKER		1
46	GB/T78	SET SCREW	M6X12	1
47		LIMIT SWITCH COVER		1
48		LIMIT SWITCH	YBLXW-5/11N1	1
49	GB/T818	PHLP HD SCREW	M4X40	2
50	D330DV-11210	BRAKE RETAINING COLLAR		1
51	D330B-14216	BRAKE PEDAL SHAFT-RIGHT		1
52	D330A-14212-1	BRAKE PEDAL		1
53	D330D-14213B	COOLANT CHUTE		1
54		LOCK CONNECTOR		2
55	D330B-14401	COOLANT TANK		1
56	D330A-92203	COOLANT PIPE FITTING		1
57		COOLANT PUMP		1
58	D330B-14211A	RIGHT STAND COVER-SIDE		1
59	GB/T97.1	FLAT WASHER	8	1
60	GB/T894.1	EXT RETAINING RING	8	1
61	D330A-11232	ROCKER PIN		1
62	GB/T1096	KEY	8X20	1
63	GB/T70	HEX SOCKET CAP SCREW	M6X10	4
64	D330A-14214-2	BRAKE LINKAGE MIDDLE		1
65	D330A-14214-3	BRAKE LINKAGE LOWER		1

**NOTE: SOME INDIVIDUAL PARTS MAY ONLY BE AVAILABLE AS AN ASSEMBLY**

ELECTRICAL ASSEMBLY 1 - DIAGRAM

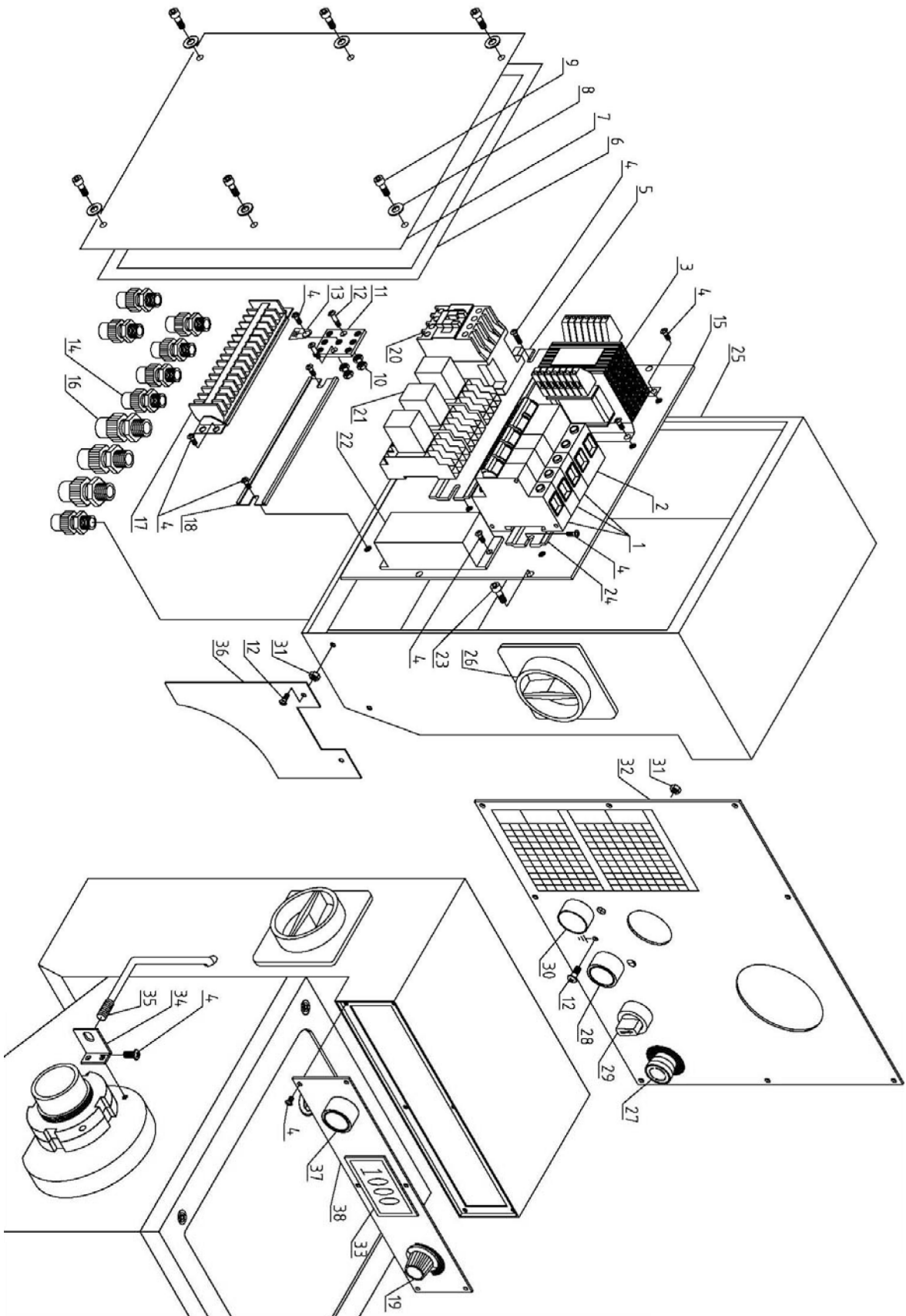

## ELECTRICAL ASSEMBLY 1 - PARTS LIST

Index No.	Part No.	Description	Size	Qty
1		PROTECTIVE CIRCUIT BREAKER	DZ47-63C3 1P	3
2		PROTECTIVE CIRCUIT BREAKER	DZ47-63C16 2P	1
3		TRANSFORMER	JBK5-100VA-TH	1
4	GB/T818-M4X6	SCREW	M4X6	24
5		FIXING RAIL CLIP		1
6		RUBBER CUSHING		4
7	D330AV-14102	COVER		1
8	GB97.1-4	WASHER	4	6
9	GB/T70- M4x10	HEX SOCKET CAP SCREW	M4x10	6
10	GB6170- M5	NUT	M5	4
11	D330A-71401	SHEET COPPER		1
12	GB818-M4X12	SCREW	M4X12	5
13		EARTH SIGN PLATE		1
14		LOCKER CONNECTING	M16X1.5	7
15	D330B-14103	BASE		1
16		LOCKER CONNECTING	M20X1.5	3
17		JUNCTION BOX		1
18		FIXING RAIL CLIP		1
19		ADJUSTABLE RESISTOR		1
20		INTERMEDIATE RELAY	JZC4-40-24V	1
21		CONTACTOR RELAY	HH54P	3
22		SOURCE	5V	1
23	GB/T70- M5X12	HEX SOCKET CAP SCREW	M5X12	4
24		FIXING RAIL CLIP		1
25	D330AV-14101	ELECTRIC BOX		1
26		POWER SWITCH	LW26-20	1
27		KNOB	LA125H-BE102C	1
28		FAST-STOP KNOB	LA125H-BE101C	1
29		BUTTON SWITCH	LAY3-11/2	1
30		POWER LIGHT	AD62-22D/S	1
31	GB6170- M4	NUT	M4	3
32		PLATE		1
33		DIGITAL DISPLAY SPINDLE SPEED		1
34	D330DV-21255	ANGLE IRON		1
35		PROBE		1
36	D330B-14220A	COVER		1
37		HAZARD WARNING LAMP	LAY7-24V	1
38		PLATE		1

**NOTE: SOME INDIVIDUAL PARTS MAY ONLY BE AVAILABLE AS AN ASSEMBLY**

ELECTRICAL ASSEMBLY 2 - DIAGRAM

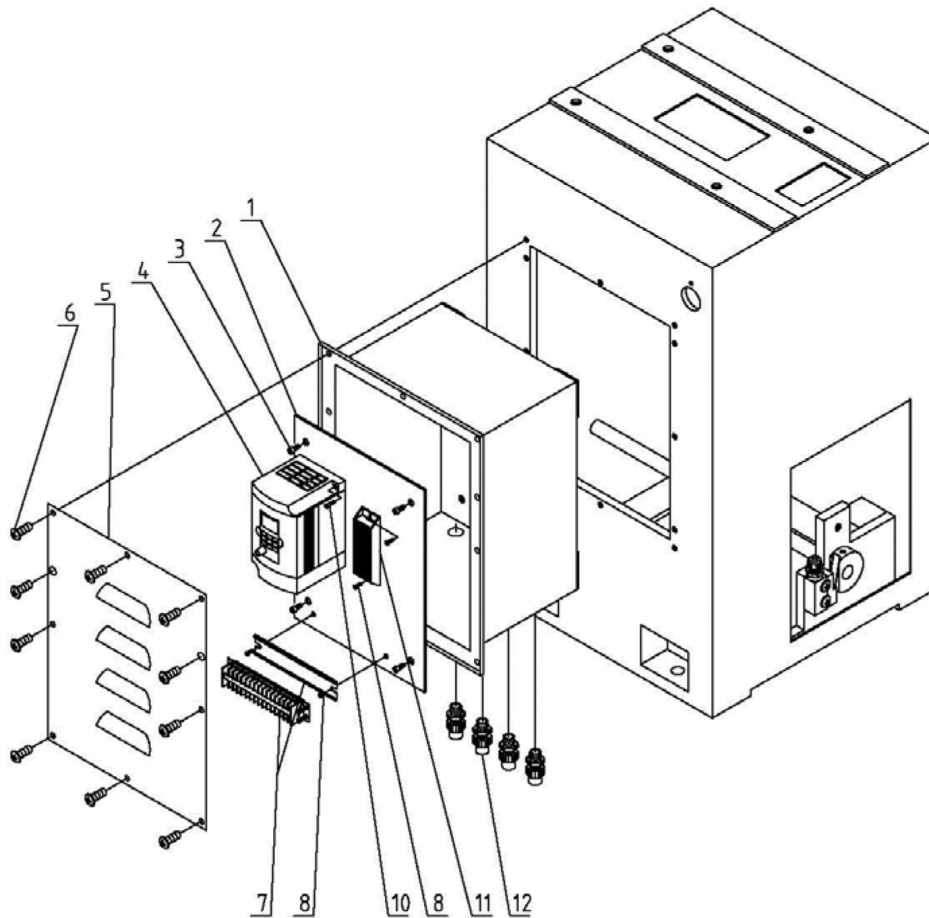

ELECTRICAL ASSEMBLY 2 - PARTS LIST

Index No.	Part No.	Description	Size	Qty
1	D330AV-14301	ELECTRIC BOX		1
2	D330AV-14303	BASE		1
3	GB/T70- M6X10	HEX SOCKET CAP SCREW	M6x10	4
4		INVERTER		1
5	D330AV-14302	COVER		1
6	GB/T818-M6X10	SCREW	M6x10	10
7		JUNCTION BOX	20 SEAT	1
8	GB818-M4X6	SCREW	M4X6	4
10	GB818-M4X12	SCREW	M4X12	2
11		BRAKING RESISTOR		1
12		LOCKER CONNECTING	M20X1.5	4

**NOTE: SOME INDIVIDUAL PARTS MAY ONLY BE AVAILABLE AS AN ASSEMBLY**

STEADY REST - DIAGRAM

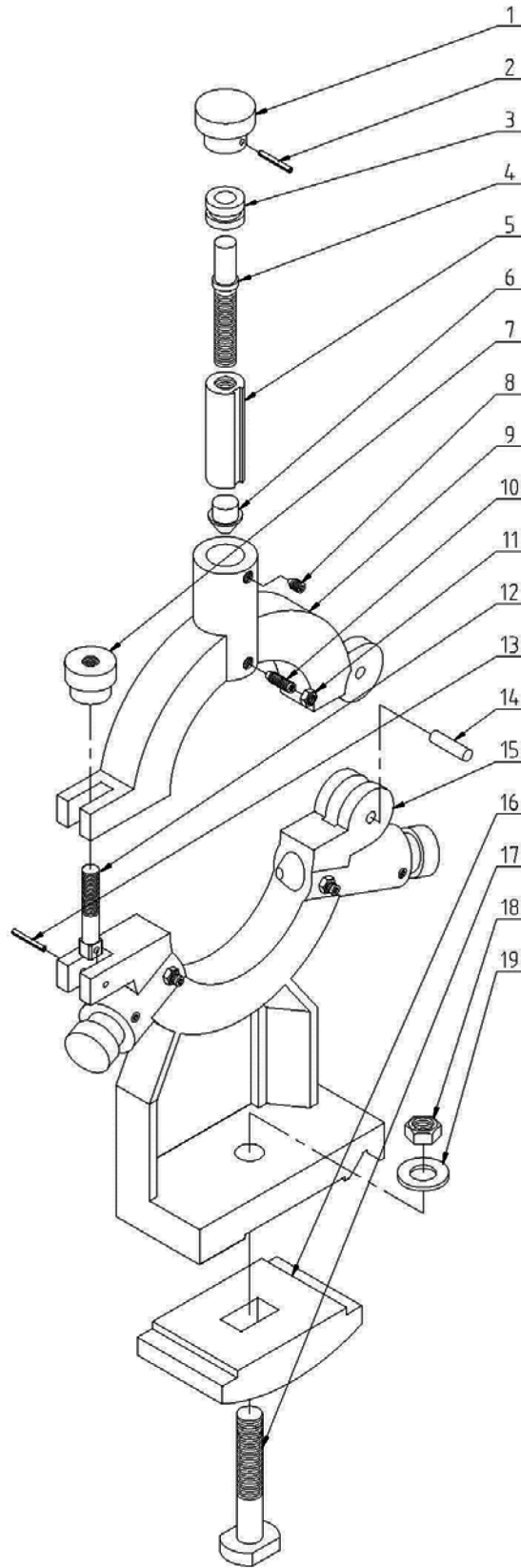

## STEADY REST - PARTS LIST

Index No.	Part No.	Description	Size	Qty
1	D330A-8205	KNOB		3
2	GB/T879-3X20	PIN	M6X8	3
3	D330A-8207	COLLAR		3
4	D330A-8206	PRESSING LEVER		3
5	D330A-8208	PRESSING COLLAR		3
6	D330A-8209	PRESSING BASE		3
7	D330A-8204	LOCKING SCREW NUT		1
8	GB/T78-M6X10	SCREW	M6X10	3
9	D330A-8202	UPPER BODY		1
10	GB/T79-M6x16	SCREW	M6x16	3
11	GB/T6170-M6	NUT	M6	3
12	D330A-8203	LOCKING LEVER		1
13	GB/T879-4x20	PIN	4x20	1
14	GB/T119-6X20	PIN	6X20	1
15	D330A-8201	BASE BODY		1
16	D330A-8210	PRESSING PLATE		1
17	D330A-8211	"T"SCREW		1
18	GB/T6170-M12	NUT	M12	1
19	GB/T97.1-12	WASHER	12	1

**NOTE: SOME INDIVIDUAL PARTS MAY ONLY BE AVAILABLE AS AN ASSEMBLY**

FOLLOW REST - DIAGRAM

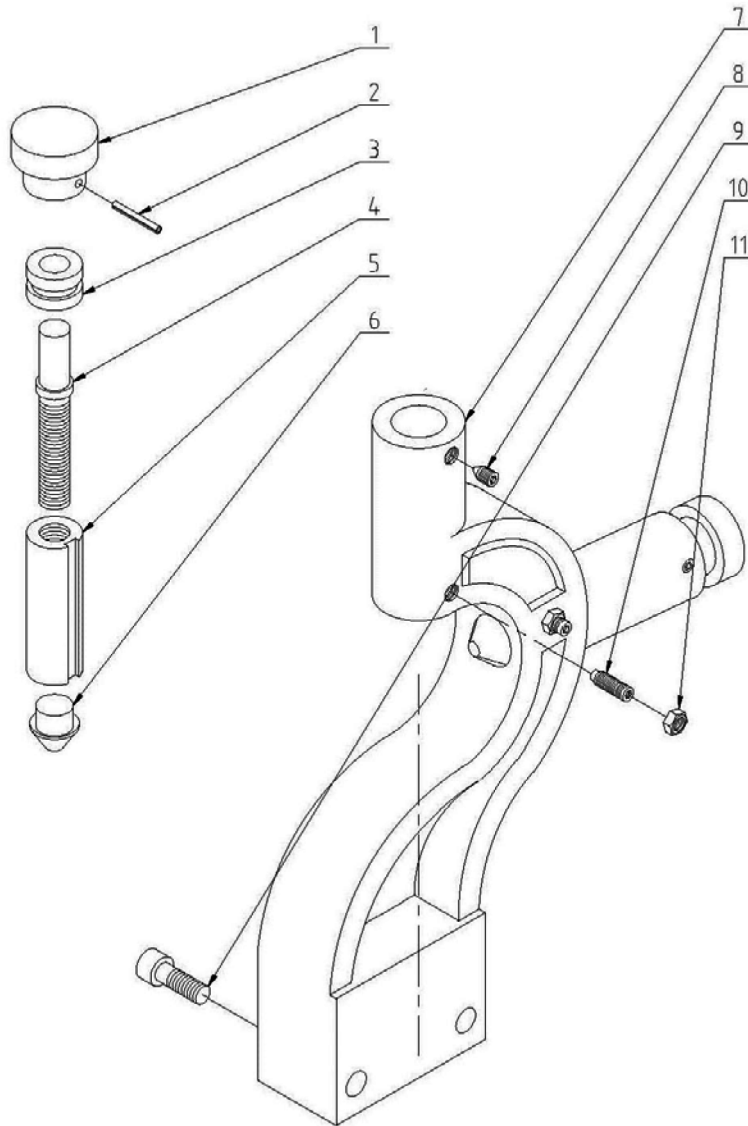

FOLLOW REST - PARTS LIST

Index No.	Part No.	Description	Size	Qty
1	D330A-8205	KNOB		2
2	GB/T879-3X20	PIN	3X20	2
3	D330A-8207	COLLAR		2
4	D330A-8304	PRESSING LEVER		2
5	D330A-8303	PRESSING COLLAR		2
6	D330A-8209	PRESSING BASE		2
7	D330A-8301	BODY		1
8	GB/T78-M6X10	SCREW	M6X10	2
9	GB/T70-M8x40	HEX SOCKET CAP SCREW	M8x40	2
10	GB/T79-M6x16	SCREW	M6x16	2
11	GB/T6170-M6	NUT	M6	2

**NOTE: SOME INDIVIDUAL PARTS MAY ONLY BE AVAILABLE AS AN ASSEMBLY**

CHUCK SAFETY GUARD - DIAGRAM (Optional)

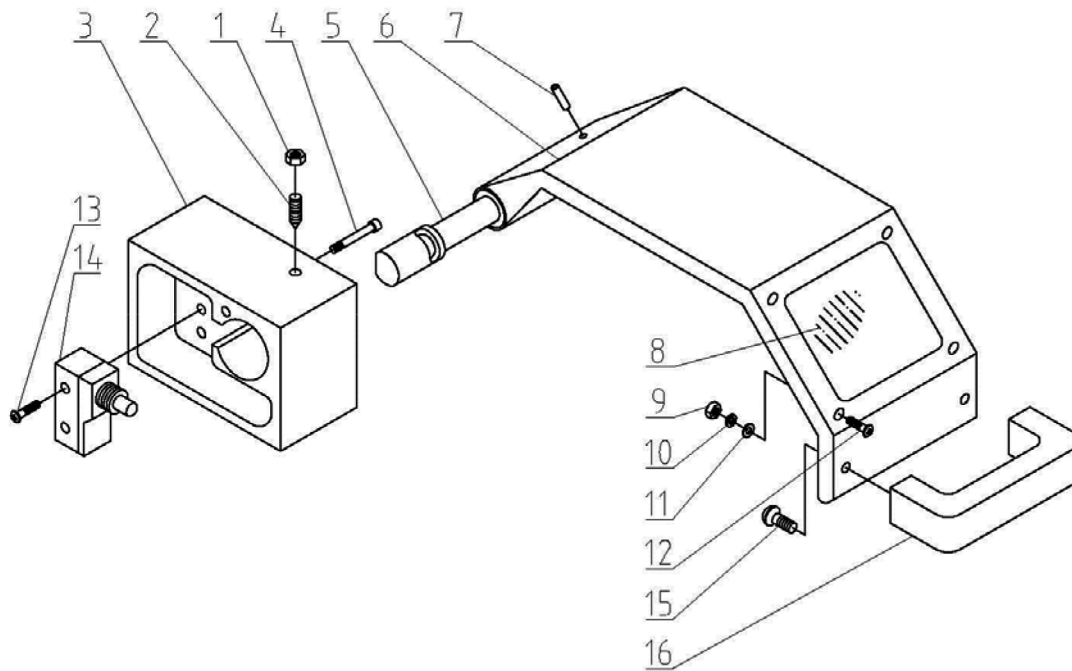

CHUCK SAFETY GUARD - PARTS LIST (Optional)

Index No.	Part No.	Description	Size	Qty
1	GB/T6170-M6	NUT	M6	1
2	GB/T79-M6 x16	SCREW	M6 x16	1
3	D330A-71101	SWITCH BOX		1
4	GB/T70-M6x 45	HEX SOCKET CAP SCREW	M6x 45	2
5	D330A-71203	SHAFT		1
6	D330A-71204	PROTECTING COVER		1
7	GB/T879-4X25	PIN	4X25	1
8	D330A-71402	COVER		1
9	GB/T6175-M3	NUT	M3	4
10	GB/T93-3	WASHER		4
11	GB/T97.1-3	WASHER	3	4
12	GB/T818-M3X12	SCREW	M3X12	4
13	GB/T818-M4X25	SCREW	M4X25	2
14		SWITCH	LXW5-11M	1
15	GB/T818-M6X8	SCREW	M6X8	2
16		HANDLE		1

**NOTE: SOME INDIVIDUAL PARTS MAY ONLY BE AVAILABLE AS AN ASSEMBLY**

LEADSCREW COVER - DIAGRAM

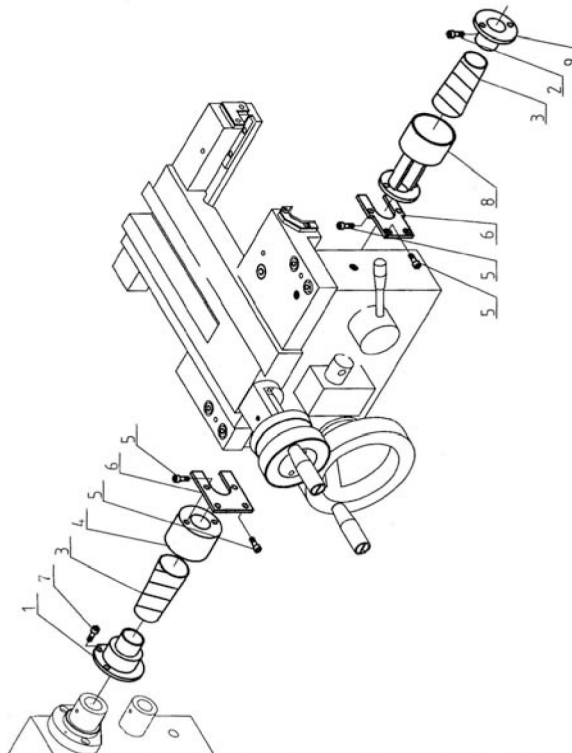

LEADSCREW COVER - SPARE PARTS

Index No.	Part No.	Description	Size	Qty
1	D330A-1030	BRACKET		1
2	GB/T70-M5×10	HEX SOCKET CAP SCREW	M5×10	2
3	D330A-F7001	SPRING COVER		2
4	D330A-1034	LEFT BRACKET		1
5	GB/T70-M6×12	HEX SOCKET CAP SCREW	M6×12	8
6	D330A-1033	BRACKET		2
7	GB/T70-M4×10	HEX SOCKET CAP SCREW	M4×10	2
8	D330B-1029G	BRACKET		1
9	D330A-1031	BRACKET		1

**NOTE: SOME INDIVIDUAL PARTS MAY ONLY BE AVAILABLE AS AN ASSEMBLY**

FEED ROD SAFETY CLUTCH - DIAGRAM

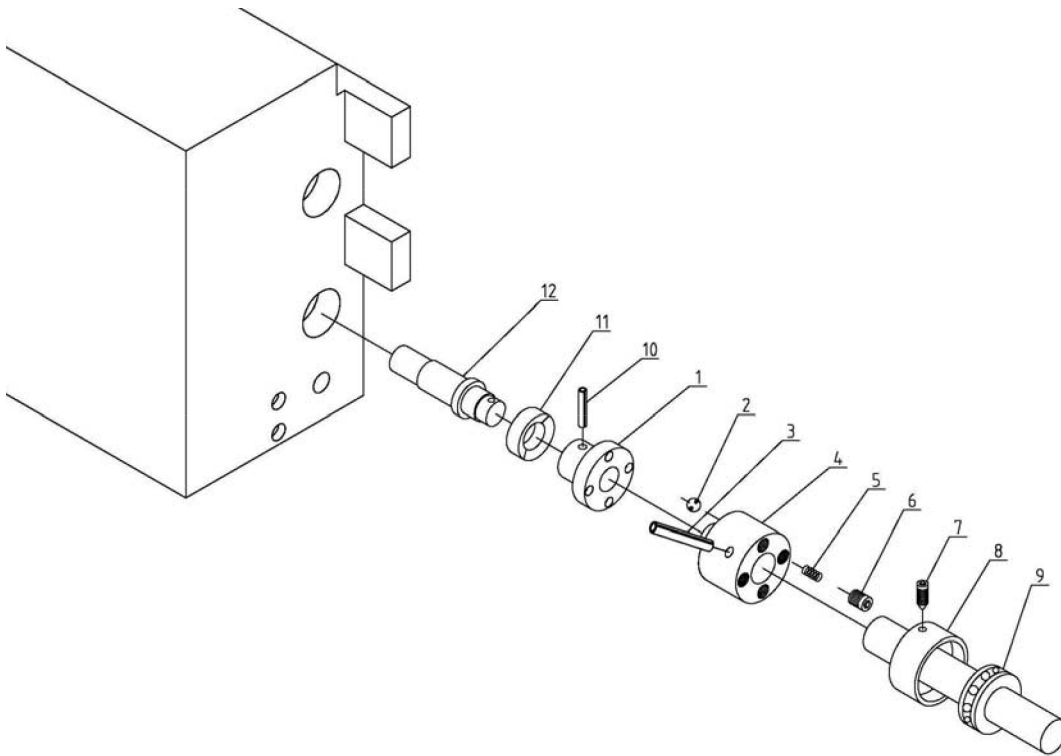

FEED ROD SAFETY CLUTCH - PARTS LIST

Index No.	Part No.	Description	Size	Qty
1	D330A-3013S/01A	CLUTCH		1
2	GB/T308-6	STEEL BALL	6	4
3	GB/T879-4X42	PIN	4X42	1
4	D330A-3020D-1	CLUTCH		1
5	GB/T1358-6X1X25	SPRING	6X1X25	4
6	GB/T77-M8X8	SCREW	M8X8	4
7	GB/T78-M6X10	SCREW	M6X10	1
8	D330A-CS004-1	COVER		1
9	GB/T301-51104	BEARING		1
10	GB/T879-5X25	PIN	5X25	1
11	GB/T9877.1-18X30X10	OIL SEAL	18X30X10	1
12	CQ6230-3013D	SHAFT		1

**NOTE: SOME INDIVIDUAL PARTS MAY ONLY BE AVAILABLE AS AN ASSEMBLY**

QUICK CHANGE TOOLPOST - DIAGRAM

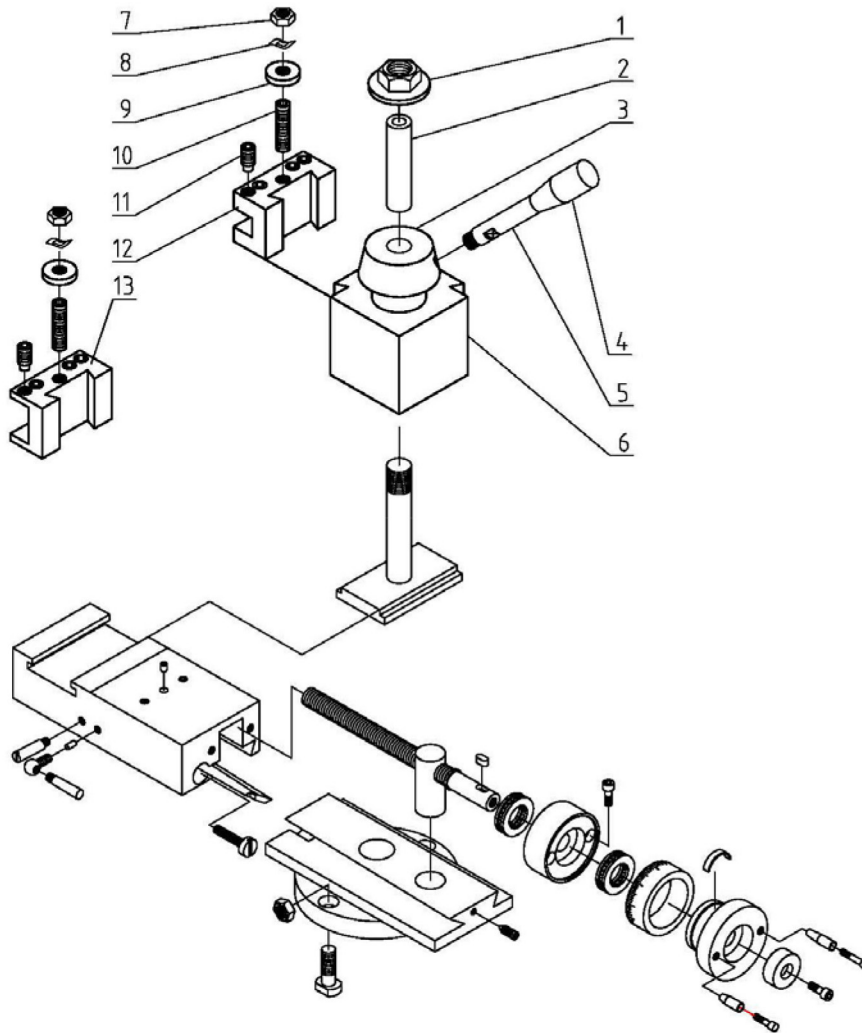

QUICK CHANGE TOOLPOST - PART LIST

Index No.	Part No.	Description	Size	Qty
1		FLANGE NUT	M16-2	1
2		SHAFT BUSHING		
3		TOOL POST LEVER HUB		
4		HANDLE		
5		LEVER		
6		BODY		
7		HEX NUT	M10-1	2
8		WAVY WASH	10MM	2
9		FLAT WASH	10MM	2
10		SET SCREW	M10-1X45	2
11		SET SCREW	M10-1X20	8
12		TOOL HOLDER 16MM		1
13		TOOL HOLDER 20MM		1

**NOTE: SOME INDIVIDUAL PARTS MAY ONLY BE AVAILABLE AS AN ASSEMBLY**

SADDLE POSITION STOP - DIAGRAM (Optional)

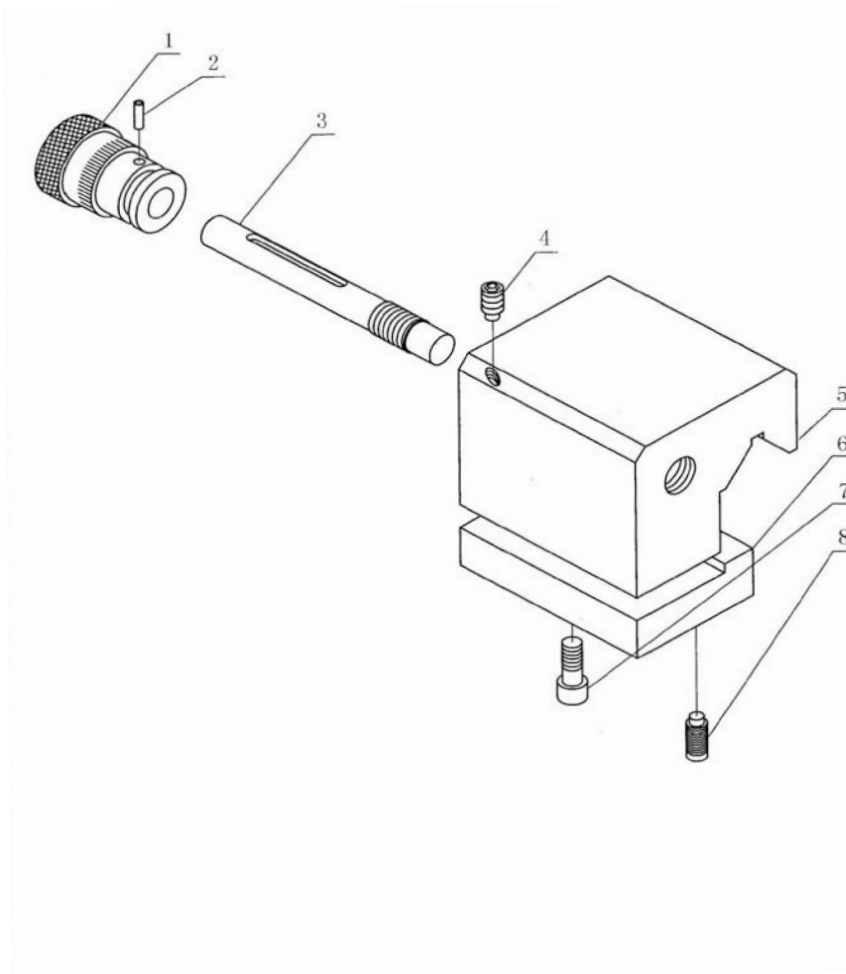

SADDLE POSITION STOP - PARTS LIST (Optional)

Index No.	Part No.	Description	Size	Qty
1	D330A-DC003	INDEX RING		1
2	GB/T879-3X6	PIN	3X6	1
3	D330A-DC004	SHAFT		1
4	GB/T79-M6X10	SCREW	M6X10	1
5	D330A-DC001	CASTING BODY		1
6	D330A-DC002	PLATE		1
7	GB/T70-M6X10	HEX SOCKET CAP SCREW	M6X10	2
8	GB/T79-M5X12	SCREW	M5X12	2

**NOTE: SOME INDIVIDUAL PARTS MAY ONLY BE AVAILABLE AS AN ASSEMBLY**





#### **ENVIRONMENT PROTECTION**

Recycle unwanted materials instead of disposing of them as waste. All tools, accessories and packaging should be sorted, taken to a recycling centre and disposed of in a manner which is compatible with the environment. When the product becomes completely unserviceable and requires disposal, drain any fluids (if applicable) into approved containers and dispose of the product and fluids according to local regulations.

IMPORTED BY

---

**HARE & FORBES**  
**MACHINERYHOUSE**

Australian Distributor

**Hare & Forbes**  
**Machineryhouse**  
Sydney - Melbourne  
Adelaide - Brisbane - Perth

**Ph: 1300 202 200**  
**[www.machineryhouse.com.au](http://www.machineryhouse.com.au)**

**MACHINERYHOUSE**

New Zealand Distributor

**Machineryhouse**  
Auckland  
Christchurch

**Ph: 0800 142 326**  
**[www.machineryhouse.co.nz](http://www.machineryhouse.co.nz)**